



Technical Publications

2251385–100

Revision 2

DRS DICOM Software V2.2 DICOM V3.0 Conformance Statement

**This document applies to the DRS3.2 / P3.2 Systems
DRS software V5.08 (or greater)**

REVISION HISTORY

REV	DATE	REASON FOR CHANGE
0	July 1999	Initial release to Direction Stock.
1	January 2000	Made change to text for more accuracy and usability.
2	March 2000	Note added chapter 2 – para 2-2-1-1-1 for PDU lenght as 0.

LIST OF EFFECTIVE PAGES

SECTION	REVISION	SECTION	REVISION
Title Page	2		
Revision History i thru ii	2		
Table of Contents i thru iv	2		
Introduction 1-1 thru 1-6	2		
Conformance Statement 2-1 thru 2-8	2		
DRS Information Object Definition 3-1 thru 3-12	2		
Modality Worklist Informaation Model Definition 4-1 thru 4-8	2		

Blank page

TABLE OF CONTENTS

SECTION 1

INTRODUCTION

1-0	OVERVIEW	1-1
1-1	OVERALL DICOM CONFORMANCE STATEMENT DOCUMENT STRUCTURE	1-2
1-2	INTENDED AUDIENCE	1-4
1-3	SCOPE AND FIELD OF APPLICATION	1-4
1-4	IMPORTANT REMARKS	1-5
1-5	REFERENCES	1-6
1-6	DEFINITIONS	1-6
1-7	SYMBOLS AND ABBREVIATIONS	1-6

SECTION 2

CONFORMANCE STATEMENT

2-0	INTRODUCTION	2-1
2-1	IMPLEMENTATION MODEL	2-1
2-1-1	Application Data Flow Diagram	2-1
2-1-2	Functional Definition of DCM AE	2-2
2-1-3	Sequencing of Real-World Activities	2-2
2-2	AE SPECIFICATIONS	2-3
2-2-1	DCM AE Specification	2-3
2-2-1-1	Association Establishment Policies	2-3
2-2-1-1-1	General	2-3
2-2-1-1-2	Number of Associations	2-3
2-2-1-1-3	Asynchronous Nature	2-4
2-2-1-1-4	Implementation Identifying Information	2-4
2-2-1-2	Association Initiation Policy	2-4
2-2-1-2-1	Real-World Activity “MANUAL TRANSMIT”	2-4
2-2-1-2-1-1	Associated Real-World Activity	2-4
2-2-1-2-1-2	Proposed Presentation Contexts	2-4
2-2-1-2-1-3	SOP Specific Conformance Statement for Image Storage SOP Classes	2-5
2-2-1-2-2	Real-World Activity GET WORKLIST	2-5
2-2-1-2-2-1	Associated Real-World Activity	2-5
2-2-1-2-2-2	Proposed Presentation Context Table	2-5
2-2-1-2-2-3	SOP Specific DICOM Conformance Statement for the Modality Worklist Information Model – FIND SOP Class	2-6
2-2-1-3	Association Acceptance Policy	2-6
2-3	COMMUNICATION PROFILES	2-7
2-3-1	Supported Communication Stacks (PS 3.8, PS 3.9)	2-7
2-3-2	OSI Stack	2-7
2-3-3	TCP/IP Stack	2-7
2-3-3-1	API	2-7
2-3-3-2	Physical Media Support	2-7
2-3-4	Point-to-Point Stack	2-7

TABLE OF CONTENTS (continued)

2-4	EXTENSIONS / SPECIALIZATIONS / PRIVATIZATIONS	2-8
2-4-1	Standard Extended /Specialized/Private SOPs	2-8
2-4-2	Private Transfer Syntaxes	2-8
2-5	CONFIGURATION	2-8
2-5-1	AE Title/Presentation Address Mapping	2-8
2-5-2	Configurable Parameters	2-8
2-6	SUPPORT OF EXTENDED CHARACTER SETS	2-8

SECTION 3

RADIO FLUOROSCOPIC (RF) INFORMATION OBJECT IMPLEMENTATION

3-0	INTRODUCTION	3-1
3-1	XRAY RF IOD IMPLEMENTATION	3-1
3-2	XRAY IOD ENTITY RELATIONSHIP MODEL	3-2
3-2-1	ENTITIES DESCRIPTION	3-3
3-2-2	DRS MAPPING OF DICOM ENTITIES	3-3
3-3	XRAY RF IMAGE IOD MODULE TABLE	3-4
3-4	INFORMATION MODULE DEFINITIONS	3-5
3-4-1	Patient Entity Module	3-5
3-4-1-1	Patient Module	3-5
3-4-2	Study Entity Modules	3-5
3-4-2-1	General Study Module	3-5
3-4-3	Series Entity Module	3-6
3-4-3-1	General Series Module	3-6
3-4-4	Equipment Entity Module	3-6
3-4-4-1	General Equipment Module	3-6
3-4-5	Image Entity Modules	3-7
3-4-5-1	General Image Module	3-7
3-4-5-2	Image Pixel Module	3-7
3-4-5-3	Cine Module	3-8
3-4-5-4	Multi Frame Module (conditional)	3-8
3-4-5-5	Frame Pointers Module (User Option)	3-8
3-4-5-6	XRAY Image Module	3-9
3-4-5-7	XRAY Acquisition Module	3-9
3-4-5-8	Display Shutter Module	3-10
3-4-5-9	VOI LUT Module	3-10
3-4-5-10	SOP Common Module	3-10
3-5	PRIVATE DATA DICTIONARY	3-11

SECTION 4

SECONDARY CAPTURE IMPLEMENTATION

4-0	INTRODUCTION	4-1
4-1	SC IMAGE IOD IMPLEMENTATION	4-1
4-2	SC IMAGE IOD ENTITY–RELATIONSHIP MODEL	4-1
4-2-1	Entities Description	4-3
4-2-2	DRS Mapping of DICOM entities	4-3
4-3	SC IMAGE IOD MODULE TABLE	4-3

TABLE OF CONTENTS (continued)

4-4 INFORMATION MODULE DEFINITIONS 4-4

 4-4-1 Patient Entity Module 4-4

 4-4-1-1 Patient Module 4-4

 4-4-2 Study Entity Module 4-4

 4-4-2-1 General Study 4-4

 4-4-3 Series Entity Module 4-5

 4-4-3-1 General Series 4-5

 4-4-4 Equipment Entity Module 4-5

 4-4-4-1 General Equipment Module 4-5

 4-4-4-2 SC Equipment Module 4-5

 4-4-5 Image Entity Module 4-6

 4-4-5-1 General Image 4-6

 4-4-5-2 Image Pixel 4-6

 4-4-5-3 VOI LUT module 4-7

 4-4-5-4 SOP Common 4-7

SECTION 5

MODALITY WORKLIST

INFORMATION MODEL DEFINITION

5-0 INTRODUCTION 5-1

5-1 MODALITY WORKLIST INFORMATION MODEL DESCRIPTION 5-1

5-2 MODALITY WORKLIST INFORMATION MODEL ENTITY-RELATIONSHIP MODEL 5-1

 5-2-1 ENTITY DESCRIPTIONS 5-3

 5-2-2 DRS Mapping of DICOM entities 5-3

5-3 INFORMATION MODEL MODULE TABLE 5-3

5-4 INFORMATION MODEL KEYS 5-4

 5-4-1 Supported Matching 5-4

 5-4-2 Scheduled Procedure Step Entity 5-4

 5-4-2-1 SOP Common Module 5-4

 5-4-2-2 Scheduled Procedure Step Module 5-5

 5-4-3 Requested Procedure Entity 5-5

 5-4-3-1 Requested Procedure Module 5-5

 5-4-4 Imaging Service Request Entity 5-6

 5-4-4-1 Imaging Service Request Module 5-6

 5-4-5 Visit Entity 5-6

 5-4-5-1 Visit Identification 5-6

 5-4-6 Patient Entity 5-6

 5-4-6-1 Patient Identification 5-6

 5-4-6-2 Patient Demographic 5-7

 5-4-6-3 Patient Medical 5-7

Blank page

SECTION 1 INTRODUCTION

1-0 OVERVIEW

This DICOM Conformance Statement is divided into Sections as described below:

Section 1 (Introduction), which describes the overall structure, intent, and references for this Conformance Statement

Section 2 (Network Conformance Statement), which specifies the GEMS equipment compliance to the DICOM requirements for the implementation of Networking features.

Section 3 *DRS XRAY RF Information Object Definition* defines the technical specifications required to interoperate with a GE Medical Systems (GEMS) network interface. They define the technical details of the Information Object Definitions (IOD's) listed in the Conformance Statement.

Section 4, *Secondary Capture Image Information Object implementation*, defines the technical specifications required to interoperate with a DICOM v3.0 network interface. They define the technical details of the Information Object definition (IOD's) listed in the Conformance statement.

Section 5 (Modality Worklist Information Model), which specifies the GEMS equipment compliance to DICOM requirements for the implementation of the Modality Worklist service.

1-1 OVERALL DICOM Conformance Statement DOCUMENT STRUCTURE

The Documentation Structure of the GEMS Conformance Statements and their relationship with the DICOM v3.0 Conformance Statements is shown in Illustration 1.

ILLUSTRATION 1
DOCUMENTATION STRUCTURE

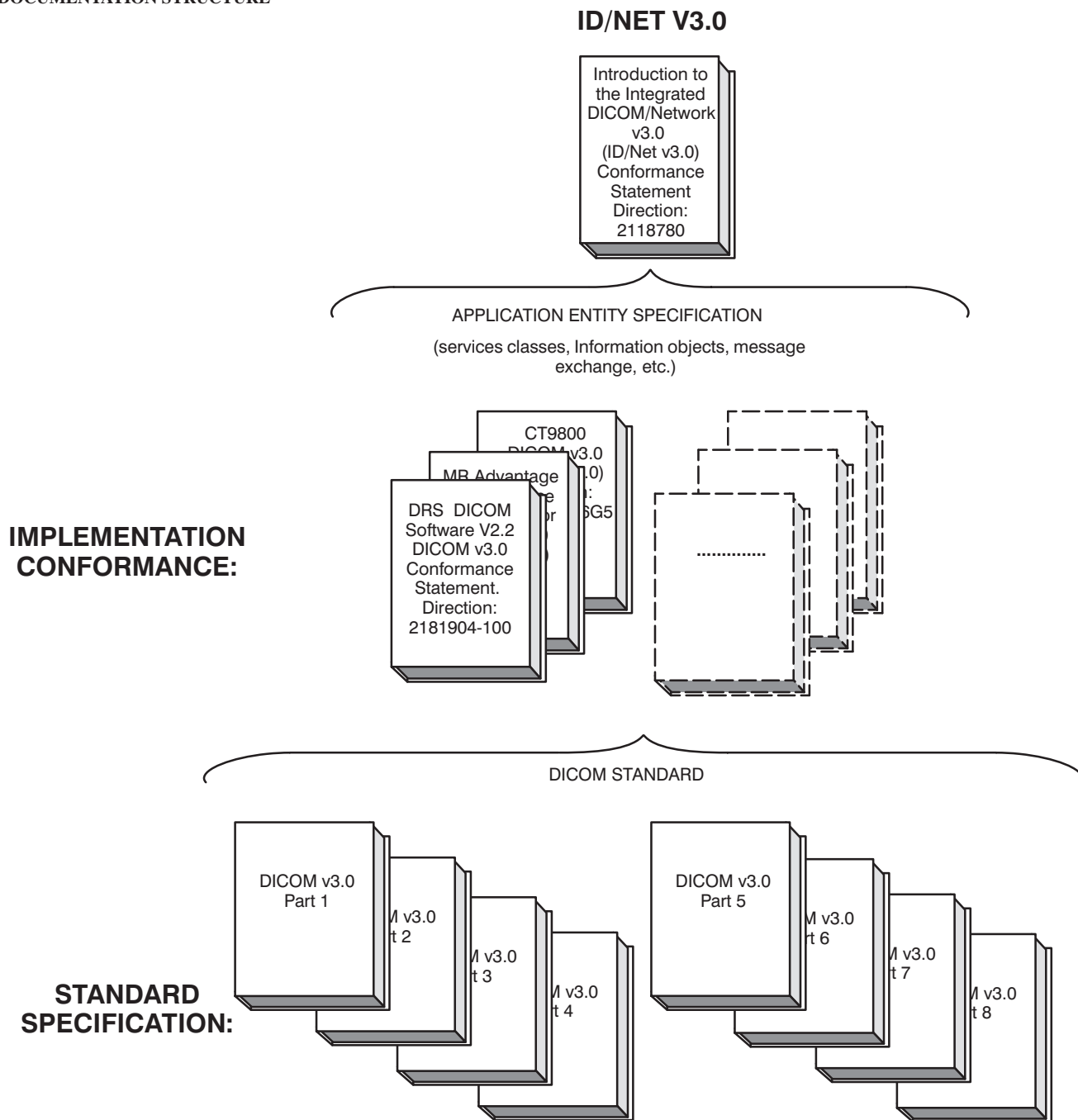

This document specifies the DICOM V3.0 implementation. It is entitled:

*DRS DICOM Software V2.2
Conformance Statement for DICOM V3.0
Direction 2181904-100*

This DICOM Conformance Statement documents the DICOM v3.0 Conformance Statement and Technical Specification required to interoperate with the GEMS network interface. Introductory information, which is applicable to all GEMS Conformance Statements, is described in the document:

*Introduction to the Integrated DICOM/Network v3.0 (ID/Net v3.0)
Conformance Statement
Direction: 2118780.*

This Introduction familiarizes the reader with DICOM terminology and general concepts. It should be read prior to reading the individual products' GEMS Conformance Statements.

The GEMS Conformance Statement, contained in this document, also specifies the Lower Layer communications which it supports (e.g., TCP/IP). However, the Technical Specifications are defined in the DICOM v3.0 Part 8 standard.

For more information including Network Architecture and basic DICOM concepts, please refer to the Introduction.

For the convenience of software developers, there is a "collector" Direction available. By ordering the collector, the Introduction described above and all of the currently published GEMS Product Conformance Statements will be received. The collector Direction is:

*ID/Net v3.0 Conformance Statements
Direction: 2117016*

For more information regarding DICOM v3.0, copies of the Standard may be obtained by written request or phone by contacting:

NEMA Publication
1300 North 17th Street
Suite 1847
Rosslyn, VA 22209 USA
Phone: (703) 841-3200

1-2 INTENDED AUDIENCE

The reader of this document is concerned with software design and/or system integration issues. It is assumed that the reader of this document is familiar with the DICOM v3.0 Standards and with the terminology and concepts which are used in those Standards.

If readers are unfamiliar with DICOM v3.0 terminology they should first refer to the document listed below, then read the DICOM v3.0 Standard itself, prior to reading this DICOM Conformance Statement document.

*Introduction to the Integrated DICOM/Network v3.0 (ID/Net v3.0)
Conformance Statement
Direction: 2118780*

1-3 SCOPE AND FIELD OF APPLICATION

It is the intent of this document, in conjunction with the *Introduction to the Integrated DICOM/Network v3.0 (ID/Net v3.0) Conformance Statement, Direction: 2118780*, to provide an unambiguous specification for GEMS implementations. This specification, called a Conformance Statement, includes a DICOM v3.0 Conformance Statement and is necessary to ensure proper processing and interpretation of GEMS medical data exchanged using DICOM v3.0. The GEMS Conformance Statements are available to the public.

The reader of this DICOM Conformance Statement should be aware that different GEMS devices are capable of using different Information Object Definitions. For example, a GEMS CT Scanner may send images using the CT Information Object, MR Information Object, Secondary Capture Object, etc.

Included in this DICOM Conformance Statement are the Module Definitions which define all data elements used by this GEMS implementation. If the user encounters unspecified private data elements while parsing a GEMS Data Set, the user is well advised to ignore those data elements (per the DICOM v3.0 standard). Unspecified private data element information is subject to change without notice. If, however, the device is acting as a "full fidelity storage device", it should retain and re-transmit all of the private data elements which are sent by GEMS devices.

1-4 IMPORTANT REMARKS

The use of these DICOM Conformance Statements, in conjunction with the DICOM v3.0 Standards, is intended to facilitate communication with GE imaging equipment. However, **by itself, it is not sufficient to ensure that inter-operation will be successful.** The **user (or user's agent)** needs to proceed with caution and address at least four issues:

- **Integration** – The integration of any device into an overall system of interconnected devices goes beyond the scope of standards (DICOM v3.0), and of this introduction and associated DICOM Conformance Statements when interoperability with non-GE equipment is desired. The responsibility to analyze the applications requirements and to design a solution that integrates GE imaging equipment with non-GE systems is the **user's** responsibility and should not be underestimated. The **user** is strongly advised to ensure that such an integration analysis is correctly performed.
- **Validation** – Testing the complete range of possible interactions between any GE device and non-GE devices, before the connection is declared operational, should not be overlooked. Therefore, the **user** should ensure that any non-GE provider accepts full responsibility for all validation required for their connection with GE devices. This includes the accuracy of the image data once it has crossed the interface between the GE imaging equipment and the non-GE device and the stability of the image data for the intended applications.

Such a validation is required before any clinical use (diagnosis and/or treatment) is performed. It applies when images acquired on GE imaging equipment are processed/displayed on a non-GE device, as well as when images acquired on non-GE equipment is processed/displayed on a GE console or workstation.

- **Future Evolution** – GE understands that the DICOM Standard will evolve to meet the user's growing requirements. GE is actively involved in the development of the DICOM v3.0 Standard. DICOM v3.0 will incorporate new features and technologies and GE may follow the evolution of the Standard. The GEMS protocol is based on DICOM v3.0 as specified in each DICOM Conformance Statement. Evolution of the Standard may require changes to devices which have implemented DICOM v3.0. **In addition, GE reserves the right to discontinue or make changes to the support of communications features (on its products) reflected on by these DICOM Conformance Statements.** The **user** should ensure that any non-GE provider, which connects with GE devices, also plans for the future evolution of the DICOM Standard. Failure to do so will likely result in the loss of function and/or connectivity as the DICOM Standard changes and GE Products are enhanced to support these changes.
- **To be informed of the evolution of the implementation described in this document, the User is advised to regularly check the GE Internet Server, accessible via anonymous ftp (GE Internet Server Address: ftp.med.ge.com, 192.88.230.11).**
- **Interaction** – It is the sole responsibility of the **non-GE provider** to ensure that communication with the interfaced equipment does not cause degradation of GE imaging equipment performance and/or function.

1-5 REFERENCES

A list of references which is applicable to all GEMS Conformance Statements is included in the *Introduction to the Integrated DICOM/Network v3.0 (ID/Net v3.0) Conformance Statement, Direction: 2118780*.

The information object implementation refers to DICOM PS 3.3 (Information Object Definition).

1-6 DEFINITIONS

A set of definitions which is applicable to all GEMS Conformance Statements is included in the *Introduction to the Integrated DICOM/Network v3.0 (ID/Net v3.0) Conformance Statement, Direction: 2118780*.

1-7 SYMBOLS AND ABBREVIATIONS

A list of symbols and abbreviations which is applicable to all GEMS Conformance Statements is included in the *Introduction to the Integrated DICOM/Network v3.0 (ID/Net v3.0) Conformance Statement, Direction: 2118780*.

**SECTION 2
CONFORMANCE STATEMENT**

2-0 introduction

This Conformance Statement (CS) specifies the GE DRS compliance to DICOM v3.0. It details the DICOM Service Classes and roles which are supported by this product. Other sections of this document describe the Information Object data elements which are used by this implementation.

Note that the format of this section strictly follows the format of DICOM Standard Part 2 (Conformance) Appendix A. Please refer to that part of the standard while reading this section.

2-1 Implementation model

2-1-1 Application Data Flow Diagram

The Basic and Specific Application models for DRS are shown in Illustration 2.

ILLUSTRATION 2
SPECIFIC AE APPLICATION MODEL

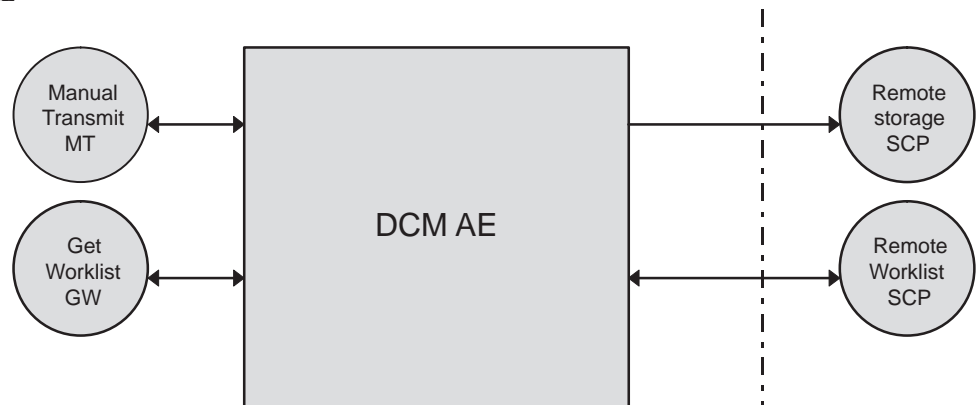

The DCM Application Entity (AE) is an application which handles all DICOM protocol communications. DCM AE is brought up when an Operator initiates a transfer on the DRS Operator Console (OC).

All remote DICOM AE Titles must be manually entered on the OC, usually at software installation time, by a GEMS Field Engineer.

There are three local real world activities: Manual Transmit (MT), Get Worklist (GW), and Verification, which can cause the DCM AE to initiate a DICOM association.

MT consists of an operator selecting a Study from the *Patient List* screen of the operator console User Interface, and choosing to send the *selected* image(s) to a selected destination.

GW consists of an operator request for the transfer of a list of Patient/Exam entries from a predefined remote HIS/RIS system. This remote His/Ris system must be DICOM compliant, and must support the Modality Worklist Management SOP class. It must support single value matching for modality (value = RF) and specified AE title.

2-1-2 Functional Definition of DCM AE

The DCM Application Entity supports the following two SCU functions (one at a time):

1. Manual Transmit:
 - Access to patient demographics and Pixel Data in the local database.
 - Build a DICOM format data set.
 - Initiate a DICOM association to send the image(s).
2. Get Worklist:
 - Build a DICOM formatted basic worklist management data request.
 - Initiate a DICOM association to send the request.
 - Wait for worklist response(s).
 - Access the local database to add new patient/exam demographic data.
 - Close the open Association.

2-1-3 Sequencing of Real-World Activities

Not Applicable

2-2 AE Specifications

2-2-1 DCM AE Specification

This Application Entity provides Standard Conformance to the following DICOM V3.0 SOP Classes as an SCU:

SOP Class Name	SOP Class UID
X-Ray Radiofluoroscopic Image Storage	1.2.840.10008.5.1.4.1.1.12.2
Secondary Capture Image Storage	1.2.840.10008.5.1.4.1.1.7
Modality Worklist Information Model – FIND	1.2.840.10008.5.1.4.31

Note: The Verification SOP Class is also proposed but not used at application level.

2-2-1-1 Association Establishment Policies

2-2-1-1-1 General

The DICOM Application Context Name (ACN), which is always offered, is:

Application Context Name	1.2.840.10008.3.1.1.1
---------------------------------	------------------------------

The Maximum Length PDU negotiation is included in all association establishment requests. The maximum length PDU for an association initiated by the DCM AE is:

Maximum Length PDU	4 Kbytes
---------------------------	-----------------

Note: 0 as PDU length is not supported in this implementation.

The SOP class Extended Negotiation is not supported.

The maximum number of Presentation Context Items that is offered is 3.

The user information items sent by this product are:

- Maximum PDU Length and,
- Implementation UID

Note: Max PDU length is not configurable at run time.

2-2-1-1-2 Number of Associations

The DCM AE initiates only one DICOM association at a time to perform an image store.

The DCM AE does not support multiple associations.

2-2-1-1-3 Asynchronous Nature

Asynchronous mode is not supported. All operations are performed synchronously.

2-2-1-1-4 Implementation Identifying Information

The Implementation UID for this GEMS Implementation is:

DRS Implementation UID	1.2.840.113619.6.75
-------------------------------	----------------------------

2-2-1-2 Association Initiation Policy

DCM AE attempts to initiate a new association for each attempt to transfer item(s) or Get Worklist Data. This association corresponds to one Real-World Activity: Manual Transfer (MT) or Get Worklist (GW).

2-2-1-2-1 Real-World Activity “MANUAL TRANSMIT”

2-2-1-2-1-1 Associated Real-World Activity

An image is sent to a DICOM Storage SCP on manual request.

2-2-1-2-1-2 Proposed Presentation Contexts

Presentation Context Table – Proposed					
Abstract Syntax		Transfer Syntax		Role	Extended Negotiation
Name	UID	Name List	UID List		
X-Ray Radiofluoroscopic Image Storage *	1.2.840.10008.5.1.4.1.1.12.2	Implicit VR Little Endian	1.2.840.10008.1.2	SCU	None
Secondary Capture Image Storage *	1.2.840.10008.5.1.4.1.1.7	Implicit VR Little Endian	1.2.840.10008.1.2	SCU	None
Modality Worklist Information Model – FIND *	1.2.840.10008.5.1.4.31	Implicit VR Little Endian	1.2.840.10008.1.2	SCU	None
Verification SOP Class *	1.2.840.10008.1.1	Implicit VR Little Endian	1.2.840.10008.1.2	SCU	None

* The SOP Classes Modality Worklist Management and Verification are proposed, but they are not used by the application for this real world activity.

The secondary capture Image is used to have a “photo” where shutters, annotations and spatial filters are processed.

2-2-1-2-1-3 SOP Specific Conformance Statement for Image Storage SOP Classes

Following are the status codes that are more specifically processed when receiving messages from a **Storage SCP** equipment:

Service Status	Status Codes	Indication	Application behavior when receiving Status Codes
Refused	A7xx	Out of resources	The “Image Transferred” logo is not displayed.
	0122	SOP Class not Supported	The “Image Transferred” logo is not displayed.
Error	Cxxx	Cannot Understand	The “Image Transferred” logo is not displayed.
	A9xx	Data Set does not match SOP Class	The “Image Transferred” logo is not displayed.
Warning	B000	Coercion of Data Elements	The “Image Transferred” logo is not displayed.
	B007	Data Set does not match SOP Class	The “Image Transferred” logo is not displayed.
	B006	Elements Discarded	The “Image Transferred” logo is not displayed.
Success	0000		

2-2-1-2-2 Real-World Activity GET WORKLIST

2-2-1-2-2-1 Associated Real-World Activity

2-2-1-2-2-2 Proposed Presentation Context Table

Presentation Context Table – Proposed					
Abstract Syntax		Transfer Syntax		Role	Extended Negotiation
Name	UID	Name List	UID List		
Modality Worklist Information Model – FIND *	1.2.840.10008.5.1.4.31	Implicit VR Little Endian	1.2.840.10008.1.2	SCU	None
X-Ray Radiofluoroscopic Image Storage *	1.2.840.10008.5.1.4.1.1.12.2	Implicit VR Little Endian	1.2.840.10008.1.2	SCU	None
Secondary Capture Image Storage *	1.2.840.10008.5.1.4.1.1.7	Implicit VR Little Endian	1.2.840.10008.1.2	SCU	None
Verification SOP Class *	1.2.840.10008.1.1	Implicit VR Little Endian	1.2.840.10008.1.2	SCU	None

* The SOP Classes XRAY RF Image Storage, Secondary Capture Image Storage and Verification are proposed, but they are not used by the application for this real world activity.

2-2-1-2-2-3 SOP Specific DICOM Conformance Statement for the Modality Worklist Information Model – FIND SOP Class

Following are the status codes that are more specifically processed when receiving messages from a **Modality Worklist** SCP equipment:

Service Status	Status Codes	Further Meaning	Application behavior when receiving Status Codes
Refused	A700	Out of resources	No exam will be created in the data base
	0122	SOP Class not Supported	No exam will be created in the data base
Failed	A900	Identifier does not match SOP Class	No exam will be created in the data base
	Cxxx	Unable to process	No exam will be created in the data base
Cancel	FE00	Matching terminated due to cancel	No exam will be created in the data base
Success	0000	Matching is complete – No final identifier is supplied	
Pending	FF00	Matches are continuing – Current Match is supplied and any Optional Keys were supported in the same manner as Required Keys.	
	FF01	Matches are continuing – Warning that one or more Optional Keys were not supported for existence for this Identifier	

2-2-1-3 Association Acceptance Policy

Not applicable.

2-3 COMMUNICATION PROFILES

2-3-1 Supported Communication Stacks (PS 3.8, PS 3.9)

DICOM Upper Layer (PS 3.8) is supported using TCP/IP.

2-3-2 OSI Stack

OSI stack not supported

2-3-3 TCP/IP Stack

The TCP/IP stack is inherited from a VRTX Operating System.

2-3-3-1 API

Not applicable to this product.

2-3-3-2 Physical Media Support

DICOM is indifferent to the physical medium over which TCP/IP executes (e.g. Ethernet V2.0, IEEE 802.3, ATM, FDDI)

Note: For more information about the physical media available on DRS, please refer to the Product Data Sheet.

2-3-4 Point-to-Point Stack

A 50-pin ACR-NEMA connection is not applicable to this product.

2-4 EXTENSIONS / SPECIALIZATIONS / PRIVATIZATIONS

2-4-1 Standard Extended /Specialized/Private SOPs

Please refer to Chapter 3 for a description of standard extended RadioFluoroscopy Image Storage SOP class.

There is no Secondary capture Private DICOM Data Dictionary.

2-4-2 Private Transfer Syntaxes

2-5 CONFIGURATION

2-5-1 AE Title/Presentation Address Mapping

Both Local AE Title and Remote AE Title are configurable. The AE Titles must be configured by a GEMS field Service Engineer during installation.

2-5-2 Configurable Parameters

The following fields are configurable for this AE (local):

- Local AE Title
- Local IP Address
- Local IP Netmask

The following fields are configurable for every remote DICOM AE:

- Remote AE Title
- Remote IP Address
- Listening TCP/IP Port Number
- Router IP Address

The following timers are configurable:

- Association Establishment Timer
- Store Timer
- Find Timer

Note: All timer configuration must be performed by a GE Field Engineer.

2-6 Support of extended character sets

The DRS will support only the ISO_IR 100 (ISO 8859-1:1987 Latin alphabet N 1. supplementary set) as extended character sets. Any incoming SOP instance that is encoded using another extended character set will not be installed in the local database.

**SECTION 3
RADIO FLUOROSCOPIC (RF) INFORMATION OBJECT IMPLEMENTATION**

3-0 INTRODUCTION

This section specifies the use of the DICOM RF Image IOD to represent the information included in RF images produced by this implementation. Corresponding attributes are conveyed using the module construct. The contents of this section are:

- 3-1: X-ray RF IOD Implementation
- 3-2: X-ray IOD Entity Relationship Model
- 3-3: X-ray RF Image IOD Module Table
- 3-4: Information Module Definitions
- 3-5: Private Data Dictionary

3-1 XRAY RF IOD IMPLEMENTATION

This Section defines the implementation of XRF image information object. It refers to the DICOM V3.0 Standard, Supplement 6 (Oct. 21, 1994) to Part 3 (Information Object Definition).

3-2 XRAY IOD ENTITY RELATIONSHIP MODEL

ILLUSTRATION 3
RF IMAGE ENTITY RELATIONSHIP DIAGRAM

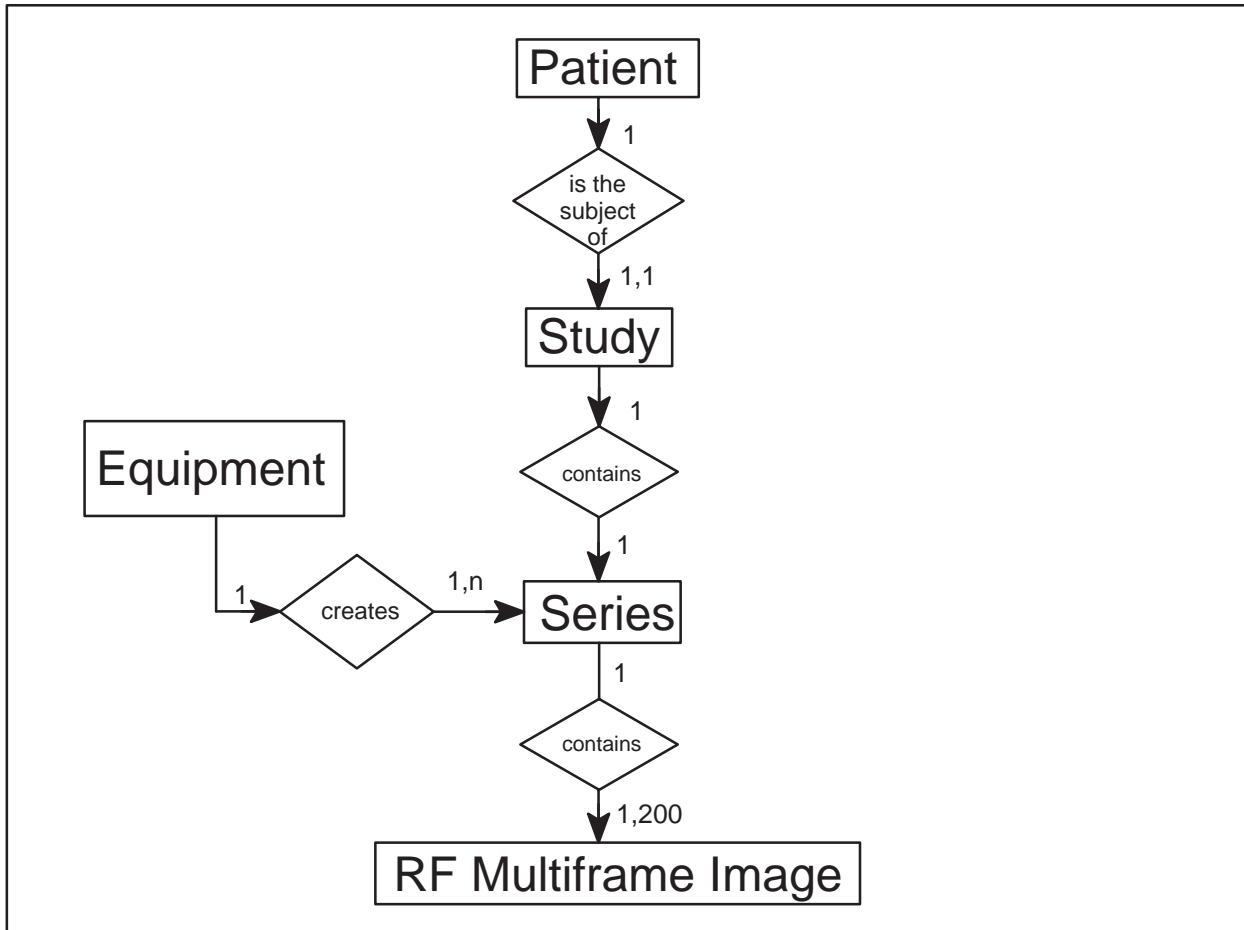

The Entity-Relationship diagram for the RF Image interoperability schema is shown in Illustration 3. In this figure, the following diagrammatic convention is established to represent the information organization:

- each entity is represented by a rectangular box
- each relationship is represented by a diamond shaped box
- the fact that a relationship exists between two entities is depicted by lines connecting the corresponding entity boxes to the relationship boxes.

The relationships are fully defined with the maximum number of possible entities in the relationship shown. In other words, the relationship between Series and Image can have up to 200 Images per Series, but the Patient to Study relationship has 1 Study for each Patient (a Patient can have more than one Study on the system, however each Study will contain all of the information pertaining to that Patient).

3-2-1 ENTITIES DESCRIPTION

Please refer to DICOM Standard Part 3 (Information Object Definitions) for a description of each of the entities contained within the RF Information Object.

3-2-2 DRS MAPPING OF DICOM ENTITIES

TABLE 1
DICOM ENTITY MAPPING

DICOM	DRS
PATIENT ENTITY	PATIENT ENTITY
STUDY ENTITY	no match
SERIE ENTITY	no match
MULTIFRAME IMAGE ENTITY	SEQUENCE ENTITY
FRAME	IMAGE

3-3 XRAY RF IMAGE IOD MODULE TABLE

Within an entity of the DICOM v3.0 RF Image Information Object Definition, attributes are grouped into related set of attributes. A set of related attributes is termed a module. A module facilitates the understanding of the semantics concerning the attributes and how the attributes are related with each other. A module grouping does not infer any encoding of information into datasets.

Table 2 identifies the defined modules within the entities which comprise the DICOM v3.0 RF Image Information Object Definition. Modules are identified by Module Name.

See DICOM v3.0 Part 3 for a complete definition of the entities, modules, and attributes.

TABLE 2
RF IMAGE INFORMATION OBJECT DEFINITION (IOD) MODULE TABLE

Entity Name	Module Name	Reference
Patient	Patient	3-4-1-1
Study	General Study	3-4-2-1
	Patient Study	3-4-2-1
Series	General Series	3-4-3-1
Equipment	General Equipment	3-4-4-1
Image	General Image	3-4-5-1
	Image Pixel	3-4-5-2
	Cine Module	3-4-5-3
	Multi Frame Module	3-4-5-4
	Frame Pointers Module	3-4-5-5
	XRAY Image Module	3-4-5-6
	XRAY Acquisition Module	3-4-5-7
	Display Shutter Module	3-4-5-8
	VOI LUT Module	3-4-5-9
	SOP Common	3-4-5-10
	Private Data Dictionary	3-5

Note: The following modules are included to convey Enumerated values, Defined Terms, and Optional Attributes Supported. Type 1 & Type 2 Attributes are also included for completeness but it should be noted that they are the same ones as defined in DICOM Part 3.

3-4 INFORMATION MODULE DEFINITIONS

Please refer to DICOM v3.0 Standard Part 3 (Information Object Definitions) for a description of each of the entities and modules contained within the RF Information Object.

3-4-1 Patient Entity Module

3-4-1-1 Patient Module

TABLE 3
PATIENT MODULE ATTRIBUTES

Attribute Name	Element Tag	Type	Notes
Patient Name	(0010,0010)	2	
Patient ID	(0010,0020)	2	
Patient Birth Date	(0010,0030)	2	
Patient Sex	(0010,0040)	2	

3-4-2 Study Entity Modules

3-4-2-1 General Study Module

TABLE 4
GENERAL STUDY ATTRIBUTES

Attribute Name	Element Tag	Type	Notes
Study Instance UID	(0020,000D)	1	(1)
Study Date	(0008,0020)	2	
Study Time	(0008,0030)	2	
Referring Physician’s Name	(0008,0090)	2	No value , zero length
Study ID	(0020,0010)	2	
Accession Number	(0008,0050)	2	No value , zero length
Study Description	(0008,1030)	3	

Note: (1) For multiframe images, the DRS allows selection of images to be sent. The Study Instance UID is generated using the number of the first image, and the image number of the multiframe. Thus, for example, if the multiframe images are 4, 5, and 6, the UID will be the same if the selected images are 4 and 5, or 4 and 6.

3-4-3 Series Entity Module

3-4-3-1 General Series Module

TABLE 5
GENERAL SERIES MODULE ATTRIBUTES

Attribute Name	Element Tag	Type	Notes
Modality	(0008,0060)	1	Enumerated Value: RF
Series Instance UID	(0020,000E)	1	
Series Number	(0020,0011)	2	value: 1
Performing Physician's Name	(0008,1050)	3	content of field "RADIOLOGIST NAME" in user interface.
Series Date	(0008,0021)	3	

3-4-4 Equipment Entity Module

3-4-4-1 General Equipment Module

TABLE 6
GENERAL EQUIPMENT MODULE ATTRIBUTES

Attribute Name	Element Tag	Type	Notes
Manufacturer	(0008,0070)	2	Defined Terms: "GE MEDICAL SYSTEMS"
Manufacturer Model Name	(0008,1090)	3	Defined Terms: "DRS"
Software Version	(0018,1020)	3	
Institution Name	(0008,0080)	3	content of field "HOSPITAL" in user menu

3-4-5 Image Entity Modules

3-4-5-1 General Image Module

TABLE 7
GENERAL IMAGE MODULE ATTRIBUTES

Attribute Name	Element Tag	Type	Notes
Image Number	(0020,0013)	2	DRS Sequence number
Patient Orientation	(0020,0020)	2C	
Image Date	(0008,0023)	2C	
Image Time	(0008,0033)	2C	
Image Type	(0008,0008)	3	Value = "ORIGINAL\PRIMARY\SINGLE PLANE"
Acquisition Date	(0008,0022)	3	
Acquisition Time	(0008,0032)	3	
Image Comments	(0020,4000)	3	
Burned In Annotation	(0028,0301)	3	YES
Lossy Image Compression	(0028,2110)	3	Value = 0 , No lossy Compression

3-4-5-2 Image Pixel Module

TABLE 8
IMAGE PIXEL MODULE ATTRIBUTES

Attribute Name	Element Tag	Type	Notes
Samples per Pixel	(0028,0002)	1	Value = 1
Photometric Interpretation	(0028,0004)	1	Defined Value: "MONOCHROME2"
Rows	(0028,0010)	1	Defined Value: 1024 or 512
Columns	(0028,0011)	1	Defined Value: 1024 or 512
Bits Allocated	(0028,0100)	1	Defined Value: 8
Bits Stored	(0028,0101)	1	Defined Value: 8
High Bit	(0028,0102)	1	Defined Value: 7
Pixel Representation	(0028,0103)	1	Defined Value: 0
Pixel Data	(7FE0,0010)	1	

3-4-5-3 Cine Module

TABLE 9
CINE MODULE ATTRIBUTES

Attribute Name	Element Tag	Type	Notes
Frame Time Vector	(0018,1065)	1C	
Start Trim	(0008,2142)	3	Value = 1
Stop Trim	(0008,2143)	3	
Recommended Display Rate	(0008,2144)	3	
Actual Frame Duration	(0018,1242)	3	Value = 40 ms

3-4-5-4 Multi Frame Module (conditional)

TABLE 10
MULTIFRAME MODULE ATTRIBUTES

Attribute Name	Element Tag	Type	Notes
Number of Frames	(0028,0008)	1	
Frame Increment Pointer	(0028,0009)	3	Value = (0018,1065)

3-4-5-5 Frame Pointers Module (User Option)

TABLE 11
FRAME POINTERS MODULE ATTRIBUTES

Attribute Name	Element Tag	Type	Notes
Frames Number of Interest	(0028,6020)	3	
Frame of Interest Description	(0028,6022)	3	
Representative Frame Number	(0028,6010)	3	Value = 1

3-4-5-6 XRAY Image Module

TABLE 12
XRAY IMAGE MODULE ATTRIBUTES

Attribute Name	Element Tag	Type	Notes
Image Type	(0008,0008)	3	Value = ORIGINAL\PRIMARY\SINGLE PLANE
Frame Increment Pointer	(0028,0009)	1C	Value = (0018,1065)
Pixel Intensity Relationship	(0028,1040)	1	Value = LIN for graphy images acquired on DRS, otherwise DISP. It is always DISP for DRS 2.2 and DRS P2.
Samples per Pixel	(0028,0002)	1	Value = 1
Photometric Interpretation	(0028,0004)	1	Defined Value: "MONOCHROME2"
Rows	(0028,0010)	1	Defined Value: 1024 or 512
Columns	(0028,0011)	1	Defined Value: 1024 or 512
Bits Allocated	(0028,0100)	1	Defined Value: 8
Bits Stored	(0028,0101)	1	Defined Value: 8
High Bit	(0028,0102)	1	Defined Value: 7
Pixel Representation	(0028,0103)	1	Defined Value: 0
Acquisition Device Processing Description	(0018,1400)	3	Filter number
Pixel Data	(7FE0,0010)	1	

3-4-5-7 XRAY Acquisition Module

TABLE 13
XRAY ACQUISITION MODULE ATTRIBUTES

Attribute Name	Element Tag	Type	Notes
Radiation Setting	(0018,1155)	1	"SC" = Fluoro image "GR" = Rad image
KVP	(0018,0060)	2	No value , zero length
XRAY tube current	(0018,1151)	2C	No value , zero length
Exposure Time	(0018,1150)	2C	No value , zero length

3-4-5-8 Display Shutter Module

TABLE 14
XRAY DISPLAY SHUTTER MODULE ATTRIBUTES

Attribute Name	Element Tag	Type	Notes
Shutter Shape	(0018,1600)	1	Value = CIRCULAR\RECTANGULAR
Shutter Left Vertical Edge	(0018,1602)	1C	
Shutter Right Vertical Edge	(0018,1604)	1C	
Shutter Upper Horizontal Edge	(0018,1606)	1C	
Shutter Lower Horizontal Edge	(0018,1608)	1C	
Center of Circular Shutter	(0018,1610)	1C	
Radius of Circular Shutter	(0018,1612)	1C	

3-4-5-9 VOI LUT Module

TABLE 15
XRAY VOI LUT MODULE ATTRIBUTES

Attribute Name	Element Tag	Type	Notes
Window Center	(0028,1050)	3	
Window Width	(0028,1051)	1C	

3-4-5-10 SOP Common Module

TABLE 16
SOP COMMON MODULE ATTRIBUTES

Attribute Name	Element Tag	Type	Notes
SOP Class UID	(0008,0016)	1	Value = 1.2.840.10008.5.1.4.1.1.12.2
SOP Instance UID	(0008,0018)	1	
Specific character set	(0008,0005)	1C	ISO_IR 100

3-5 PRIVATE DATA DICTIONARY

TABLE 17
ADDITIONAL INFORMATION

Attribute Name	Element Tag	Type	VR	VM
Private Creator DRS_1	(0037,00xx)	3	LO	1
Referring Department	(0037,xx10)	3	LO	1
Screen Number	(0037,xx20)	3	US	1
Left Orientation	(0037,xx40)	3	SH	1
Right Orientation	(0037,xx42)	3	SH	1
Inversion	(0037,xx50)	3	CS	1
DSA	(0037,xx60)	3	US	1

Attribute Name	Element Tag	Value
Private Creator DRS_1	(0037,00xx)	GEMS_DRS_1

Blank page

**SECTION 4
SECONDARY CAPTURE IMPLEMENTATION**

4-0 Introduction

This section specifies the use of the DICOM v3.0 Secondary Capture Image IOD to represent the information included in Secondary Capture images produced by this implementation. Corresponding attributes are conveyed using the module construct.

4-1 SC Image IOD Implementation

This section defines the implementation of SC image information object. It refers to the DICOM V3.0 Standard, Part 3 (Information Object definition).

4-2 SC Image IOD Entity–Relationship Model

ILLUSTRATION 4
SC Image Entity Relationship Diagram

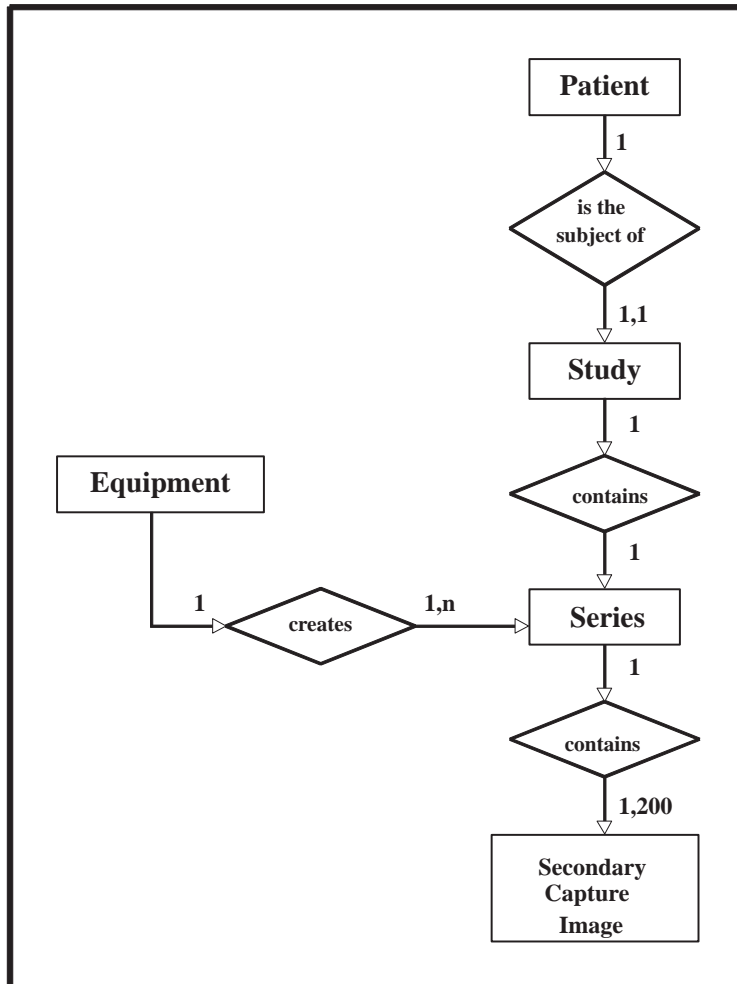

The Entity-Relationship diagram for the SC Image interoperability schema is shown in Illustration 4. The following diagrammatic convention is established to represent the information organisation :

- each entity is represented by a rectangular box
- each relationship is represented by a diamond shaped box
- the fact that a relationship exists between two entities is depicted by lines connecting the corresponding entity boxes to the relationship boxes.

The relationships are fully defined with the maximum number of possible entities in the relationship shown.

4-2-1 Entities Description

Refer to DICOM Standard Part 3 (Information Object Definitions) for a description of each of the entities contained within the Secondary Capture Image Information Object Definition.

4-2-2 DRS Mapping of DICOM entities

TABLE 18
DICOM ENTITY MAPPING

DICOM	DRS
PATIENT ENTITY	PATIENT ENTITY
STUDY ENTITY	no match
SERIE ENTITY	no match
SECONDARY CAPTURE ENTITY	One frame of a SEQUENCE ENTITY

4-3 SC Image IOD Module Table

Within an entity of the DICOM v3.0 SC Image Information Object Definition, attributes are grouped into related set of attributes. A set of related attributes is termed a module. A module facilitates the understanding of the semantics concerning the attributes and how the attributes are related with each other. A module grouping does not infer any encoding of information into datasets.

Table 19 identifies the defined modules within the entities, which comprise the DICOM v3.0 SC Image Information object Definition. Modules are identified by Module Name.

See DICOM v3.0 Part 3 for a complete definition of the entities, modules, and attributes.

TABLE 19
SC IMAGE INFORMATION OBJECT DEFINITION (IOD) MODULE TABLE

Entity Name	Module Name	Reference
Patient	Patient	4-4-1-1
Study	General Study	4-4-2-1
Series	General Series	4-4-3-1
Equipment	General Equipment	4-4-4-1
	SC Equipment	4-4-4-2
Image	General Image	4-4-5-1
	Image Pixel	4-4-5-2
	VOI LUT	4-4-5-3
	SOP Common	4-4-5-4

4-4 Information Module Definitions

Please refer to DICOM v3.0 Standard Part 3 (Information Object Definition) for a description of each of the entities and modules contained within the SC Information Object.

4-4-1 Patient Entity Module

4-4-1-1 Patient Module

TABLE 20
PATIENT MODULE ATTRIBUTES

Attribute Name	Element Tag	TP	Notes
Patient's Name	0010, 0010	2	
Patient ID	0010, 0020	2	
Patient's Birth Date	0010, 0030	2	
Patient's Sex	0010, 0040	2	

4-4-2 Study Entity Module

4-4-2-1 General Study

TABLE 21
GENERAL STUDY ATTRIBUTES

Attribute Name	Element Tag	TP	Notes
Study Instance UID	0020, 000D	1	
Study Date	0008, 0020	2	
Study Time	0008, 0030	2	
Referring Physicians' Name	0008, 0090	2	No value, zero length
Study ID	0020, 0010	2	
Accession number	0008, 0050	2	No value, zero length
Study Description	0008, 1030	3	

4-4-3 Series Entity Module

4-4-3-1 General Series

TABLE 22
GENERAL SERIES ATTRIBUTES

Attribute Name	Element Tag	TP	Notes
Modality	0008, 0060	1	value : RF
Series Instance UID	0020, 000E	1	
Series Number	0020, 0011	2	value : 1
Series Date	0008, 0021	3	
Performing Physician's Name	0008, 1050	3	

4-4-4 Equipment Entity Module

4-4-4-1 General Equipment Module

TABLE 23
GENERAL EQUIPMENT MODULE ATTRIBUTES

Attribute Name	Element Tag	TP	Notes
Manufacturer	0008, 0070	3	GE MEDICAL SYSTEMS
Software Version	0018,1020	3	
Institution name	0008, 0080	3	Configuration field.
Manufacturer Model Name	0008, 1090		DRS

4-4-4-2 SC Equipment Module

TABLE 24
SC EQUIPMENT MODULE ATTRIBUTES

Attribute Name	Element Tag	TP	Notes
Conversion Type	0008, 0064	1	WSD
Modality	0008, 0060	3	RF
Secondary Capture Device Manufacturer	0018, 1016	3	GE MEDICAL SYSTEMS
Secondary Capture Device Manufacturer's Model Name	0018, 1018	3	DRS
Software Version for SC	0018,1019	3	

4-4-5 Image Entity Module

4-4-5-1 General Image

TABLE 25
GENERAL IMAGE MODULE ATTRIBUTES

Attribute Name	Element Tag	TP	Notes
Image Number	0020,0013	2	DRS Sequence number
Image Date	0008,0023	2C	
Image Time	0008,0033	2C	
Image Type	0008,0008	3	DERIVED\SECONDARY\ SINGLE PLANE
Patient Orientation	0020,0020	2C	No value, Zero length
Image comments	0020,4000	3	
Burned In Annotation	0028, 0301	3	YES
Lossy Image Compression	0028, 02110	3	Value: "0" "0"

4-4-5-2 Image Pixel

TABLE 26
IMAGE PIXEL MODULE ATTRIBUTES

Attribute Name	Element Tag	TP	Notes
Samples per Pixel	0028, 0002	1	1
Photometric Interpretation	0028, 0004	1	MONOCHROME2
Rows	0028, 0010	1	1024
Columns	0028, 0011	1	1024
Bits Allocated	0028, 0100	1	16
Bits Stored	0028, 0101	1	8
High Bit	0028, 0102	1	7
Pixel Representation	0028, 0103	1	0
Pixel Data	7FE0, 0010	1	

4-4-5-3 VOI LUT module

TABLE 27
VOI LUT MODULE ATTRIBUTES

Attribute Name	Element Tag	TP	Notes
Window Center	0028, 1050	3	
Window Width	0028, 1051	1C	

4-4-5-4 SOP Common

TABLE 28
SOP COMMON MODULE ATTRIBUTES

Attribute Name	Element Tag	TP	Notes
SOP Class UID	0008, 0016	1	1.2.840.10008.5.1.4.1.1.7
SOP Instance UID	0008, 0018	1	(1)
Specific Character Set	0008, 0005	1C	ISO-IR-100

Note: (1) The SOP Instance UID is generated using the number of the image that is processed to create the SC object.

Blank page

SECTION 5 MODALITY WORKLIST INFORMATION MODEL DEFINITION

5–0 introduction

This section specifies the use of the DICOM Modality Worklist Information Model used to organize data and against which a Modality Worklist Query will be performed. The contents of this section are:

- 5–1: Information Model Description
- 5–2: Information Model Entity–Relationship Model
- 5–3: Information Model Module Table
- 5–4: Information Model Keys

5–1 Modality Worklist Information Model Description

5–2 Modality Worklist Information Model Entity–Relationship Model

The Entity–Relationship diagram for the Modality Worklist Information Model schema is shown in Illustration 5. It represents the information that composes a Worklist Item. In this figure, the following diagrammatic convention is established to represent the information organization:

- each entity is represented by a rectangular box
- each relationship is represented by a diamond shaped box.
- the fact that a relationship exists between two entities is depicted by lines connecting the corresponding entity boxes to the relationship boxes.

ILLUSTRATION 5
MODALITY WORKLIST INFORMATION MODEL E/R DIAGRAM

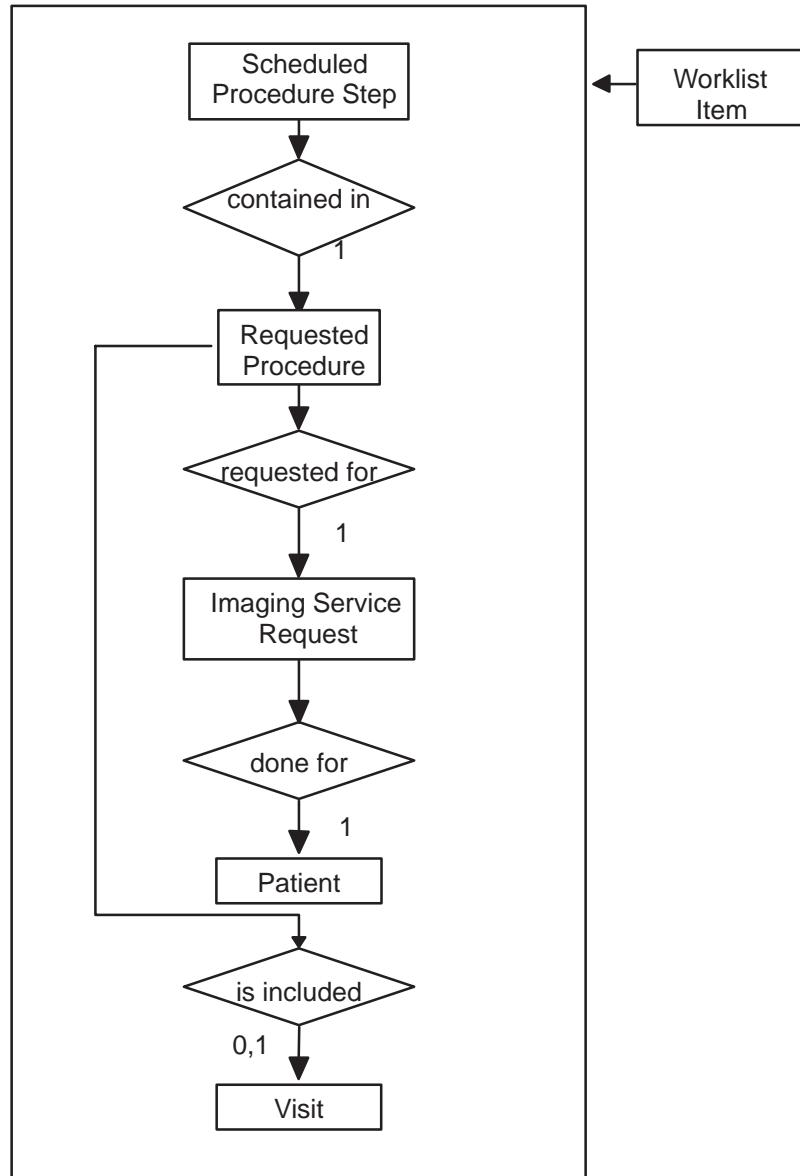

5–2–1 ENTITY DESCRIPTIONS

Please refer to DICOM Standard PS 3.3. (Information Object Definitions) and PS 3.4 (Service Class Specifications) for a description of each of the Entities contained within the Modality Worklist Information Model.

5–2–2 DRS Mapping of DICOM entities

TABLE 29
MAPPING OF DICOM ENTITIES TO DRS ENTITIES

DICOM	DRS Entity
Scheduled Procedure Step	
Requested Procedure	Exam
Imaging Service Request	Exam
Visit	
Patient	Patient

5–3 INFORMATION MODEL MODULE TABLE

Within an entity of the DICOM v3.0 Modality Worklist Information Model, attributes are grouped into related set of attributes. A set of related attributes is termed a module. A module facilitates the understanding of the semantics concerning the attributes and how the attributes are related with each other. A module grouping does not infer any encoding of information into datasets.

Table 30 identifies the defined modules within the entities which comprise the DICOM v3.0 Modality Worklist Information Model. Modules are identified by Module Name.

See DICOM v3.0 PS 3.3 and PS 3.4 for a complete definition of the entities, modules, and attributes.

TABLE 30
MODALITY WORKLIST INFORMATION MODEL MODULES

Entity Name	Module name	Reference
Scheduled Procedure Step	SOP Common	5–4–2–1
	Scheduled Procedure Step	5–4–2–2
Requested Procedure	Requested Procedure	5–4–3–1
Imaging Service Request	Imaging Service Request	5–4–4–1
Visit	Visit Identification	5–4–5–1
Patient	Patient Identification	5–4–6–1
	Patient Demographic	5–4–6–2
	Patient Medical	5–4–6–3

5-4 INFORMATION Model Keys

Please refer to DICOM Standard PS 3.3. (Information Object Definitions) and PS 3.4 (Service Class Specifications) for a description of each of the Entities contained within the Modality Worklist Information Model.

The following Module descriptions are included to specify what data elements are supported and what type of matching can be applied. It should be noted that they are the same ones as defined in the DICOM v3.0 Standard PS 3.4 (Service Class Specifications).

5-4-1 Supported Matching

Following are the types of matching that can be requested by the implementation :

- Single Value matching
- Universal Matching

Note: Please refer to the tables below for further information about single value matching.

5-4-2 Scheduled Procedure Step Entity

5-4-2-1 SOP Common Module

TABLE 31
SOP COMMON MODULE ATTRIBUTES

Attribute Name	Tag	Expected Matching Key Type	Expected Returned Key Type	Mapped into the Image	Note
Specific Character Set	(0008,0005)	O	1C	No	Single value matching supported. Value = ISO_IR 100

5-4-2-2 Scheduled Procedure Step Module

TABLE 32
SCHEDULED PROCEDURE STEP MODULE ATTRIBUTES

Attribute Name	Tag	Expected Matching Key Type	Expected Returned Key Type	Mapped into the Image	Note
Scheduled Procedure Step Sequence	(0040,0100)	R	1	No	
>Scheduled Station AE Title	(0040,0001)	R	1	No	Single value matching supported and dynamically configurable.
>Scheduled Procedure Step Start Date	(0040,0002)	R	1	No	
>Scheduled Procedure Step Start Time	(0040,0003)	R	1	No	
>Modality	(0008,0060)	R	1	Yes	Single value matching supported. Value = RF
>Scheduled Performing Physician's Name	(0040,0006)	R	2	Yes	This field is user modifiable
>Scheduled Station Name	(0040,0010)	O	2	No	Single value matching supported and dynamically configurable.
>Scheduled Procedure Step ID	(0040,0009)	O	1	No	

5-4-3 Requested Procedure Entity

5-4-3-1 Requested Procedure Module

TABLE 33
REQUESTED PROCEDURE MODULE ATTRIBUTES

Attribute Name	Tag	Expected Matching Key Type	Expected Returned Key Type	Mapped into the Image	Note
Requested Procedure ID	(0040,1001)	O	1	Yes	This field is user modifiable
Requested Procedure Description	(0032,1060)	O	1C	Yes	This field is user modifiable
Study Instance UID	(0020,000D)	O	1	Yes	

5-4-4 Imaging Service Request Entity

5-4-4-1 Imaging Service Request Module

TABLE 34
IMAGING SERVICE REQUEST MODULE ATTRIBUTES

Attribute Name	Tag	Expected Matching Key Type	Expected Returned Key Type	Mapped into the Image	Note
Accession Number	(0008,0050)	O	2	No	
Referring Physician's Name	(0008,0090)	O	2	No	

5-4-5 Visit Entity

5-4-5-1 Visit Identification

TABLE 35
VISIT IDENTIFICATION MODULE ATTRIBUTES

Attribute Name	Tag	Expected Matching Key Type	Expected Returned Key Type	Mapped into the Image	Note
Admission ID	(0038,0010)	O	2	No	
Institution Name	(0008,0080)	O	3	No	

5-4-6 Patient Entity

5-4-6-1 Patient Identification

TABLE 36
PATIENT IDENTIFICATION MODULE ATTRIBUTES

Attribute Name	Tag	Expected Matching Key Type	Expected Returned Key Type	Mapped into the Image	Note
Patient's Name	(0010,0010)	R	1	Yes	This field is user modifiable
Patient ID	(0010,0020)	R	1	Yes	This field is user modifiable

5-4-6-2 Patient Demographic

TABLE 37
PATIENT DEMOGRAPHIC MODULE ATTRIBUTES

Attribute Name	Tag	Expected Matching Key Type	Expected Returned Key Type	Mapped into the Image	Note
Patients Birth Date	(0010,0030)	O	2	Yes	This field is user modifiable
Patient's Sex	(0010,0040)	O	2	Yes	This field is user modifiable
Patient's Weight	(0010,1030)	O	2	No	
Confidentiality constraint on patient data	(0040,3001)	O	2	No	
Patient's Size	(0010,1020)	O	3	No	
Patient's Address	(0010,1040)	O	3	No	
Patient's Telephone Numbers	(0010,2154)	O	3	No	

5-4-6-3 Patient Medical

TABLE 38
PATIENT MEDICAL MODULE ATTRIBUTES

Attribute Name	Tag	Expected Matching Key Type	Expected Returned Key Type	Mapped into the Image	Note
Pregnancy Status	(0010,21C0)	O	2	No	
Additional Patient History	(0010,21B0)	O	3	No	

Blank page



GE Medical Systems

*GE Medical Systems: Telex 3797371
P.O. Box 414, Milwaukee, Wisconsin 53201 U.S.A.
(Asia, Pacific, Latin America, North America)*

*GE Medical Systems — Europe: Telex 261794
Shortlands, Hammersmith, London W6 8BX U.K.*