



GE Healthcare

Technical Publications

**2246811-2-1EN
Revision 1**

Senographe 2000 D Acquisition Workstation

**CONFORMANCE STATEMENT
for DICOM V3.0**

do not duplicate

Copyright© 2008 By General Electric Co.

THIS PAGE LEFT INTENTIONALLY BLANK

REVISION HISTORY

REFERENCE	DATE	REASON FOR CHANGE
2246811-100 rev0	31 st May 1999	Creation of Document
2246811-100 rev1	20 March 2000	FFDM M4
2246811-100 rev2	September 24, 2001	Onyx M4: Removed sentence describing editing of config. file in section 6.5.
2246811-1-100 rev1	June 23, 2006	Released for Alnitak F3 Value 2 in table 0-11 of section 4.5.5.6: PARALLEL replaced by FOCUSED. Acquisition Device Processing Description in table 0-13 of section 4.5.5.8: added GEMS_FFDM_PV and GEMS_FFDM_AC_1 descriptions. Acquisition Device Processing Code in table 0-13 of section 4.5.5.8: added PREMIUM_VIEW code. VOI LUT Function added in table 0-20 of section 4.5.5.15.
2246811-2-1EN rev1	June 20, 2008	Released for Onyx M410 General Equipment Module Attributes in table 0-5 of section 4.5.4.1: added or deleted description for Manufacturer's Model Name, Device Serial Number and Software Versions attributes. DX Detector Module Attributes in table 0-14 of section 4.5.5.9: corrected type and description for Imager Pixel Spacing attribute. Private Creator Identification in table 0-1 of section 4.6: corrected VR value for Clinical View attribute (LO replaced by CS).

LIST OF EFFECTIVE PAGES

PAGES	REVISION	PAGES	REVISION
pp. i - iv	1		
pp. 1 - 82	1		

THIS PAGE LEFT INTENTIONALLY BLANK

TABLE OF CONTENTS

1.	INTRODUCTION	1
1.1	OVERVIEW.....	1
1.2	OVERALL DICOM CONFORMANCE STATEMENT DOCUMENT STRUCTURE.....	2
1.3	INTENDED AUDIENCE	3
1.4	SCOPE AND FIELD OF APPLICATION	3
1.5	IMPORTANT REMARKS	4
1.6	REFERENCES.....	4
1.7	DEFINITIONS	4
1.8	SYMBOLS AND ABBREVIATIONS	4
2.	NETWORK CONFORMANCE STATEMENT	5
2.1	INTRODUCTION.....	5
2.2	IMPLEMENTATION MODEL	5
2.3	AE SPECIFICATIONS	9
2.4	COMMUNICATION PROFILES	21
2.5	EXTENSIONS / SPECIALIZATIONS / PRIVATIZATIONS	22
2.6	CONFIGURATION.....	22
2.7	SUPPORT OF EXTENDED CHARACTER SETS.....	23
3.	MEDIA STORAGE CONFORMANCE STATEMENT	25
3.1	INTRODUCTION.....	25
3.2	IMPLEMENTATION MODEL	25
3.3	AE SPECIFICATIONS	28
3.4	AUGMENTED AND PRIVATE APPLICATION PROFILES	30
3.5	EXTENSIONS, SPECIALIZATIONS, PRIVATIZATIONS OF SOP CLASSES AND TRANSFER SYNTAXES	30
3.6	CONFIGURATION.....	30
3.7	SUPPORT OF EXTENDED CHARACTER SETS.....	30

4.	DIGITAL MAMMOGRAPHY X-RAY INFORMATION OBJECT IMPLEMENTATION	31
4.1	INTRODUCTION.....	31
4.2	MG IOD IMPLEMENTATION	31
4.3	MG ENTITY-RELATIONSHIP MODEL.....	31
4.4	IOD MODULE TABLE.....	32
4.5	INFORMATION MODULE DEFINITIONS.....	33
4.6	PRIVATE DATA DICTIONARY	47
4.7	MAMMOGRAPHY VIEW CODES	47
5.	STUDY ROOT QUERY/RETRIEVE INFORMATION MODEL DEFINITION.....	49
5.1	INTRODUCTION.....	49
5.2	STUDY ROOT INFORMATION MODEL DESCRIPTION	49
5.3	STUDY ROOT INFORMATION MODEL ENTITY-RELATIONSHIP MODEL.....	49
5.4	INFORMATION MODEL KEYS	50
5.5	PRIVATE DATA DICTIONARY	52
6.	MODALITY WORKLIST INFORMATION MODEL DEFINITION	53
6.1	INTRODUCTION.....	53
6.2	MODALITY WORKLIST INFORMATION MODEL DESCRIPTION.....	53
6.3	MODALITY WORKLIST INFORMATION MODEL ENTITY-RELATIONSHIP MODEL.....	53
6.4	INFORMATION MODEL MODULE TABLE.....	55
6.5	INFORMATION MODEL KEYS	56
6.6	PRIVATE DATA DICTIONARY	60
7.1	INTRODUCTION.....	61
7.2	IMPLEMENTATION MODEL	61
7.3	AE SPECIFICATIONS.....	62
7.4	COMMUNICATION PROFILES.....	64
7.5	EXTENSIONS / SPECIALIZATIONS / PRIVATIZATIONS	65
7.6	CONFIGURATION.....	65
7.7	SUPPORT OF EXTENDED CHARACTER SETS.....	66

8. PRINT MANAGEMENT SOP CLASS DEFINITION 67

8.1 INTRODUCTION.....67

8.2 PRINT MANAGEMENT SOP CLASS DEFINITIONS67

9. STORAGE COMMITMENT PUSH MODEL SOP CLASS DEFINITION 79

9.1 INTRODUCTION.....79

9.2 STORAGE COMMITMENT PUSH MODEL SOP CLASS DEFINITION79

THIS PAGE LEFT INTENTIONALLY BLANK

1. INTRODUCTION

1.1 OVERVIEW

This DICOM Conformance Statement is divided into Sections as described below:

Section 1 (Introduction), which describes the overall structure, intent, and references for this Conformance Statement

Section 2 (Network Conformance Statement), which specifies the GEMS equipment compliance to the DICOM requirements for the implementation of Networking features.

Section 3 (Media Storage Conformance Statement), which specifies the GEMS equipment compliance to the DICOM requirements for the implementation of Media Storage features.

Section 4 (Digital Mammography X-Ray Information Object Implementation), which specifies the GEMS equipment compliance to DICOM requirements for the implementation of a Digital Mammography X-ray Information Object Implementation feature.

Section 5 (Study Root Query/Retrieve Information Model), which specifies the GEMS equipment compliance to DICOM requirements for the implementation of the Study Root Query/Retrieve Information Model feature.

Section 6 (Modality Worklist Information Model Definition), which specifies the GEMS equipment compliance to DICOM requirements for the implementation of Basic Worklist Management Service feature.

Section 7 (Network Print SCU Conformance Statement), which specifies the GEMS equipment compliance to DICOM requirements for the implementation of the Network Print feature.

Section 8 (Network Print Management SOP Class Definition), which specifies the GEMS equipment compliance to DICOM requirements for the implementation of the Network Print Management SOP Class.

Section 9 (Storage Commitment Push Model), which specifies the GEMS equipment compliance to DICOM requirements for the implementation of the Storage Commitment Push Service feature.

1.2 OVERALL DICOM CONFORMANCE STATEMENT DOCUMENT STRUCTURE

The Documentation Structure of the GEMS Conformance Statements and their relationship with the DICOM v3.0 Conformance Statements is shown in the Illustration below.

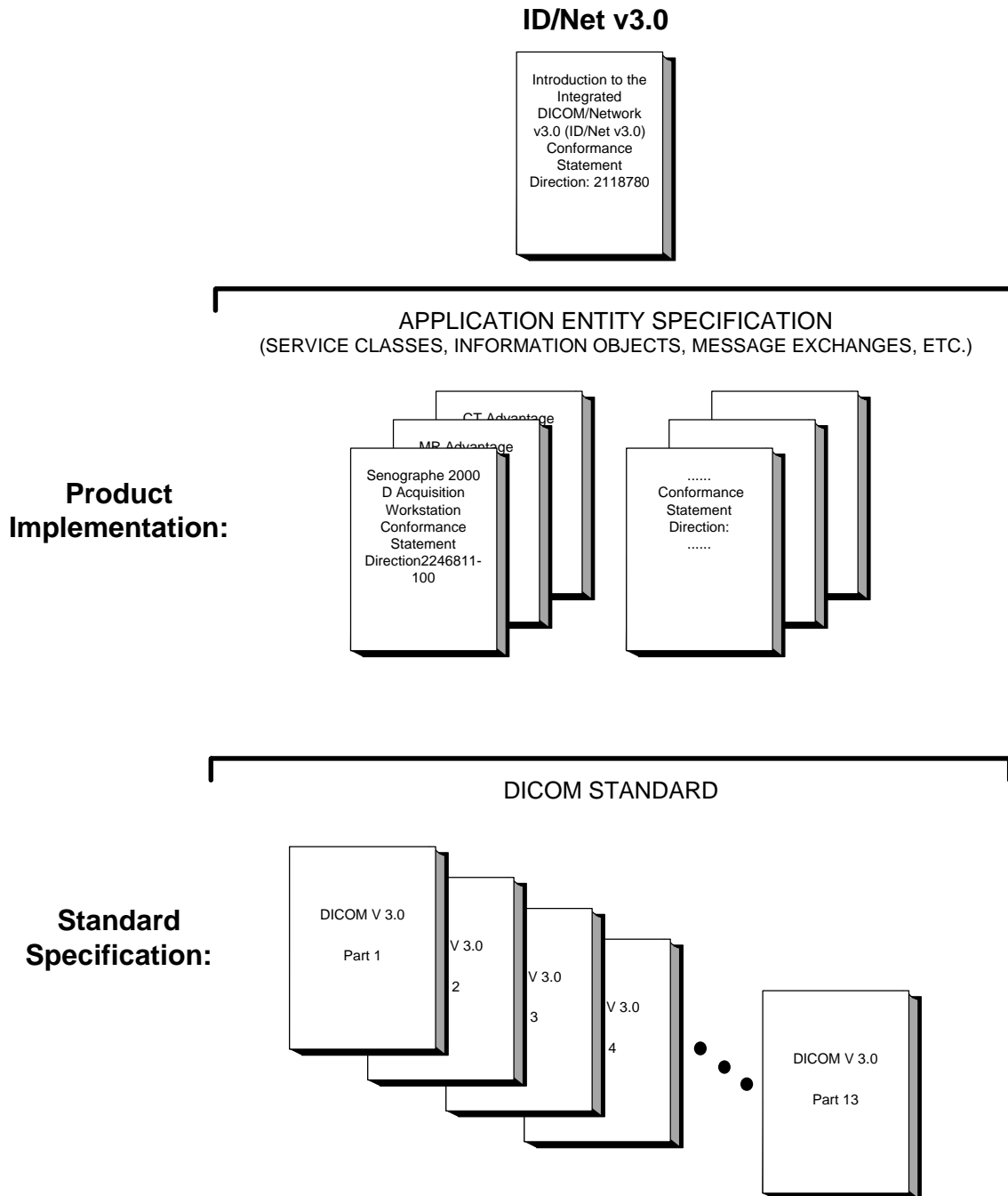

This document specifies the DICOM v3.0 implementation. It is entitled:

*Senographe 2000 D Acquisition Workstation
Conformance Statement for DICOM v3.0
Direction 2246811-100*

This DICOM Conformance Statement documents the DICOM v3.0 Conformance Statement and Technical Specification required to interoperate with the GEMS network interface. Introductory information, which is applicable to all GEMS Conformance Statements, is described in the document:

*Introduction to the Integrated DICOM/Network v3.0 (ID/Net v3.0)
Conformance Statement
Direction: 2118780.*

This Introduction familiarizes the reader with DICOM terminology and general concepts. It should be read prior to reading the individual products' GEMS Conformance Statements.

The GEMS Conformance Statement, contained in this document, also specifies the Lower Layer communications which it supports (e.g., TCP/IP). However, the Technical Specifications are defined in the DICOM v3.0 Part 8 standard.

For more information including Network Architecture and basic DICOM concepts, please refer to the Introduction.

For more information regarding DICOM v3.0, copies of the Standard may be obtained by written request or phone by contacting:

NEMA Publication
1300 North 17th Street
Suite 1847
Rosslyn, VA 22209
USA
Phone: (703) 841-3200

1.3 INTENDED AUDIENCE

The reader of this document is concerned with software design and/or system integration issues. It is assumed that the reader of this document is familiar with the DICOM v3.0 Standards and with the terminology and concepts which are used in those Standards.

If readers are unfamiliar with DICOM v3.0 terminology they should first refer to the document listed below, then read the DICOM v3.0 Standard itself, prior to reading this DICOM Conformance Statement document.

*Introduction to the Integrated DICOM/Network v3.0 (ID/Net v3.0)
Conformance Statement
Direction: 2118780*

1.4 SCOPE AND FIELD OF APPLICATION

It is the intent of this document, in conjunction with the *Introduction to the Integrated DICOM/Network v3.0 (ID/Net v3.0) Conformance Statement, Direction: 2118780*, to provide an unambiguous specification for GEMS implementations. This specification, called a Conformance Statement, includes a DICOM v3.0 Conformance Statement and is necessary to ensure proper processing and interpretation of GEMS medical data exchanged using DICOM v3.0. The GEMS Conformance Statements are available to the public.

The reader of this DICOM Conformance Statement should be aware that different GEMS devices are capable of using different Information Object Definitions. For example, a GEMS CT Scanner may send images using the CT Information Object, MR Information Object, Secondary Capture Object, etc. Included in this DICOM Conformance Statement are the Module Definitions which define all data elements used by this GEMS implementation. If the user encounters unspecified private data elements while parsing a GEMS Data Set, the user is well advised to ignore those data elements (per the DICOM v3.0 standard). Unspecified private data element information is subject to change without notice. If,

however, the device is acting as a "full fidelity storage device", it should retain and re-transmit all of the private data elements which are sent by GEMS devices.

1.5 IMPORTANT REMARKS

The use of these DICOM Conformance Statements, in conjunction with the DICOM v3.0 Standards, is intended to facilitate communication with GE imaging equipment. However, **by itself, it is not sufficient to ensure that inter-operation will be successful.** The user (or user's agent) needs to proceed with caution and address at least four issues:

- **Integration** - The integration of any device into an overall system of interconnected devices goes beyond the scope of standards (DICOM v3.0), and of this introduction and associated DICOM Conformance Statements when interoperability with non-GE equipment is desired. The responsibility to analyze the applications requirements and to design a solution that integrates GE imaging equipment with non-GE systems is the **user's** responsibility and should not be underestimated. The **user** is strongly advised to ensure that such an integration analysis is correctly performed.
- **Validation** - Testing the complete range of possible interactions between any GE device and non-GE devices, before the connection is declared operational, should not be overlooked. Therefore, the **user** should ensure that any non-GE provider accepts full responsibility for all validation required for their connection with GE devices. This includes the accuracy of the image data once it has crossed the interface between the GE imaging equipment and the non-GE device and the stability of the image data for the intended applications.

Such a validation is required before any clinical use (diagnosis and/or treatment) is performed. It applies when images acquired on GE imaging equipment are processed/displayed on a non-GE device, as well as when images acquired on non-GE equipment is processed/displayed on a GE console or workstation.

- **Future Evolution** - GE understands that the DICOM Standard will evolve to meet the user's growing requirements. GE is actively involved in the development of the DICOM v3.0 Standard. DICOM v3.0 will incorporate new features and technologies and GE may follow the evolution of the Standard. The GEMS protocol is based on DICOM v3.0 as specified in each DICOM Conformance Statement. Evolution of the Standard may require changes to devices which have implemented DICOM v3.0. **In addition, GE reserves the right to discontinue or make changes to the support of communications features (on its products) reflected on by these DICOM Conformance Statements.** The user should ensure that any non-GE provider, which connects with GE devices, also plans for the future evolution of the DICOM Standard. Failure to do so will likely result in the loss of function and/or connectivity as the DICOM Standard changes and GE Products are enhanced to support these changes.
- **To be informed of the evolution of the implementation described in this document, the User is advised to regularly check the GE Internet Server, accessible via anonymous ftp (GE Internet Server Address: ftp.med.ge.com, 192.88.230.11).**
- **Interaction** - It is the sole responsibility of the **non-GE provider** to ensure that communication with the interfaced equipment does not cause degradation of GE imaging equipment performance and/or function.

1.6 REFERENCES

A list of references which is applicable to all GEMS Conformance Statements is included in the *Introduction to the Integrated DICOM/Network v3.0 (ID/Net v3.0) Conformance Statement, Direction: 2118780.*

The information object implementation refers to DICOM PS 3.3 (Information Object Definition) and DICOM Supplement 32: Digital X-Ray Supplement

1.7 DEFINITIONS

A set of definitions which is applicable to all GEMS Conformance Statements is included in the *Introduction to the Integrated DICOM/Network v3.0 (ID/Net v3.0) Conformance Statement, Direction: 2118780.*

1.8 SYMBOLS AND ABBREVIATIONS

A list of symbols and abbreviations which is applicable to all GEMS Conformance Statements is included in the *Introduction to the Integrated DICOM/Network v3.0 (ID/Net v3.0) Conformance Statement, Direction: 2118780.*

2. NETWORK CONFORMANCE STATEMENT

2.1 INTRODUCTION

This section of the DICOM Conformance Statement specifies the compliance to DICOM conformance requirements for the relevant **Networking** features on this GEMS product. Note that the format of this section strictly follows the format defined in DICOM Standard PS 3.2 (Conformance). Please refer to that part of the standard while reading this section.

The details of the DICOM conformance related to other Information Objects and Information Models supported by this product are included in subsequent sections of this DICOM Conformance Statement. SENOGRAPHE 2000 D is an Integrated Digital X-Ray Mammography Imaging System:

It uses DICOM services to export/import images to/from remote workstations.

It uses DICOM Storage Commitment service to transfer ownership of images to a remote workstation supporting storage commitment such as an archive system.

It allows a user to query for and display DICOM modality worklist information from a remote hospital or radiology department information system computer. For example, a user may wish to query for all procedures scheduled to be performed on the system. In this situation, SENOGRAPHE 2000 D Acquisition Workstation is providing the DICOM Modality Worklist SOP Class service as a service class user (SCU).

2.2 IMPLEMENTATION MODEL

2.2.1 Application Data Flow Diagram

The Basic and Specific Application models for this device are shown in the following Illustration:

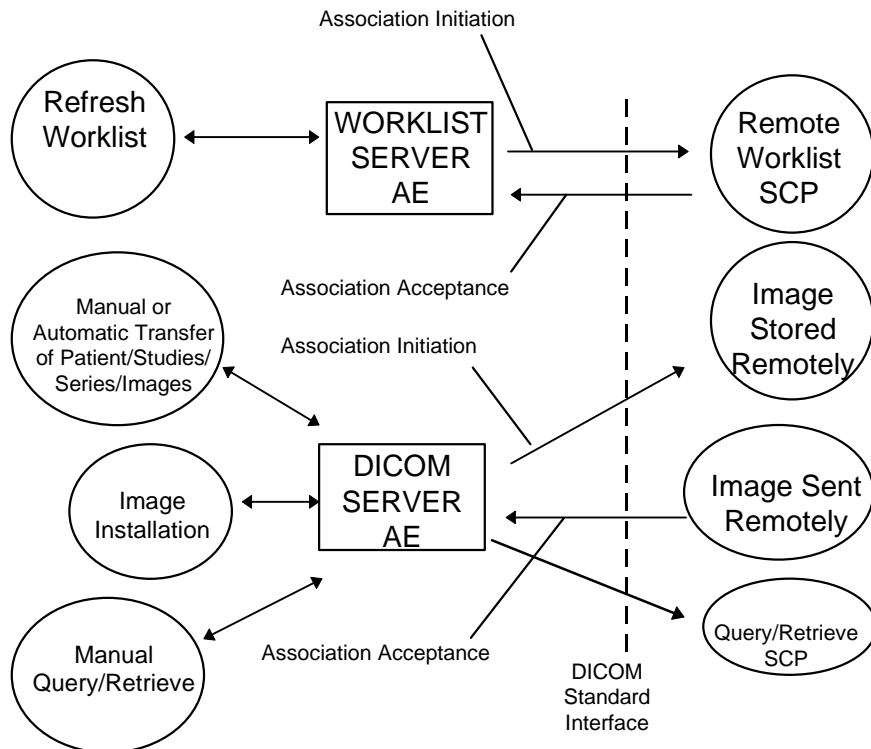

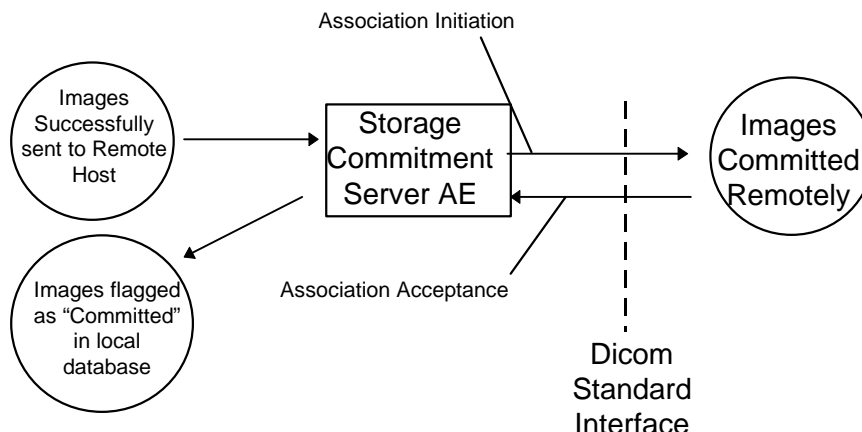

Note: Please also refer to sections 3 and 7 of the current document for Media Storage and Network Print Management SCU Conformance Statement.

2.2.2 Functional Definition of AE's

DICOM SERVER AE:

The DICOM SERVER Application Entity (AE) is an application which handles DICOM protocol communication. DICOM SERVER AE is automatically brought up when the SENOGRAPHE 2000 D Acquisition Workstation is powered on.

The DICOM SERVER AE is invoked by the following Real World Activities:

- Manual Transfer of Patients/Studies/Series/Images from the Senographe 2000 D Acquisition Workstation to a Remote Host.

For this operation, the operator selects patients, studies, series or images on the console browser and then sends the selected patients, studies, series or images on one or several remote DICOM AE by a drag and drop on the icon that represents the wanted remote DICOM AE.

All remote DICOM AE must be manually configured on the SENOGRAPHE 2000 D Acquisition Workstation by an operator or by a field engineer.

The declaration of remote DICOM AE is done through the "NETWORK MANAGEMENT" option of the Browser toolkit menu

- Automatic transfer of Images from the Senographe 2000 D Acquisition Workstation to a Remote Host.
For this operation, the transfer of images is triggered automatically. When Auto-Push is ON, all images generated during an acquisition session are automatically sent to the defined auto-push remote hosts when the user closes the exam.

The setting of Auto-Push status (ON/OFF) and Auto-Push remote host is done through the "MEDICAL APPLICATION PREFERENCES" option of the Browser toolkit menu.

The visualization of the transfer status is done on a specific message window.

- Images Sent Remotely from a Remote DICOM AE to the SENOGRAPHE 2000 D Acquisition Workstation.
When images are installed in the local database, they are displayed in the SENOGRAPHE 2000 D Acquisition Workstation browser.
- Manual Query/Retrieve

For this operation, the operator queries a remote database to obtain a list of data at Patient/Study/Series/Image by clicking on the icon that represents the wanted remote DICOM AE.

Once the remote browser is displayed, the operator can retrieve images of the SOP Classes supported by the SENOGRAPHE 2000 D Acquisition Workstation from the remote DICOM AE.

The query is selective based on criteria described below in the document.

The DICOM SERVER AE initiates the following operations:

- Access to patient demographics and pixel data in the local database.
- Build a DICOM format data set.
- Initiate a DICOM association to send DICOM SOP Classes to a remote DICOM AE.
- Initiate a DICOM association to ask for remote patient demographics.
- Initiate a DICOM association to ask for transmit images from a remote DICOM AE to SENOGRAPHE 2000 D Acquisition Workstation.

The DICOM SERVER AE waits for association requests from Remote AE:

- Answer to DICOM associations transmitting DICOM SOP Classes to be stored on the SENOGRAPHE 2000 D Acquisition Workstation.
- Answer to DICOM associations transmitting Verification SOP Class to the SENOGRAPHE 2000 D Acquisition Workstation.

WORKLIST SERVER AE:

The WORKLIST SERVER AE is automatically brought up when the SENOGRAPHE 2000 D Acquisition Workstation is powered on.

All remote Worklist SCP must be manually configured on the SENOGRAPHE 2000 D Acquisition Workstation by a field engineer. The configuration of remote Worklist SCP is done through the option “Worklist Management” of the Browser Toolkit Menu.

The WORKLIST SERVER AE is invoked by the real world activity: “Refresh Worklist”.

For this operation, the user clicks on the REFRESH WORKLIST button of the Worklist screen in order to obtain latest modality worklist from the RIS. The WORKLIST SERVER sends a query defined by the user to remote AE’s and returns the results to the user interface.

The WORKLIST SERVER AE initiates the following functions:

- Build the Worklist query according to the criteria defined by the user in the Query Definition Window.
- Send the query to Worklist Provider: Initiates a DICOM association with the Worklist Provider. If the remote Worklist Provider accepts a presentation context applicable to modality worklist, the WORKLIST SERVER AE issues a modality worklist query request via the C-FIND service.

STORAGE COMMITMENT SERVER AE:

The STORAGE COMMITMENT SERVER AE is automatically brought up when the SENOGRAPHE 2000 D Acquisition Workstation is powered on.

The STORAGE COMMITMENT SERVER AE is invoked by the Real World Activities: “Images successfully sent to a remote host supporting Storage Commitment”.

The declaration of remote host supporting Storage Commitment is done through a specific menu (known as NETWORK MANAGEMENT menu).

When STORAGE COMMITMENT SERVER AE receives a successful commitment for some images, it flags them as “Committed” in the local database.

The STORAGE COMMITMENT SERVER AE initiates the following operations:

- Initiate a DICOM association to ask a remote host (Storage Commitment SCP) storage commitment on specific images.

The STORAGE COMMITMENT SERVER AE waits for association requests from Remote Storage Commitment AE:

- Answer to DICOM associations transmitting Storage Commitment Notification (N-EVENT-REPORT)

2.2.3 Sequencing of Real-World Activities

DICOM SERVER AE:

In case of automatic transfer of images to a remote host:

1. User set Auto-Push ON and defines auto-push remote hosts.
2. User starts an exam.
3. User acquires images
4. User clicks on CLOSE EXAM
5. Images are sent to auto-push remote hosts.

WORKLIST SERVER AE:

The user will usually refresh the Worklist before the image acquisition in order to get the very latest information from the RIS.

1. Upon user request, the system initiates a modality worklist query (as a modality worklist SCU) to the modality worklist SCP with a given set of query parameters.
2. The modality worklist SCP returns responses which match the query parameters.
3. Items from the returned worklist responses are filtered according to the query parameters
4. Only the items matching the query parameters are presented to the user.
5. Each item of the returned worklist responses selected for image acquisition is included in acquired DICOM images related to the responses.

STORAGE COMMITMENT SERVER AE

1. The user selects the images and send them to a remote host.
2. If the remote host was declared on the system as Storage Commitment Provider and if the images are successfully sent, then N-ACTION-RQ request is sent to Storage Commitment Provider
3. Waits for N-ACTION-RSP from Storage Commitment Provider
4. On reception of failure in N-ACTION-RSP, Storage Commitment AE logs the error, displays a pop-up and stops.
5. On reception of success, Storage Commitment AE is ready to receive at any time from Storage Commitment Provider the N-EVENT-REPORT-RQ notification.
6. On reception of N-EVENT-REPORT-RQ notification from Storage Commitment Provider, system flags the images in the database as committed.
7. When all images are flagged, Storage Commitment AE sends a N-EVENT-REPORT-RSP to the Storage Commitment Provider

2.3 AE SPECIFICATIONS

2.3.1 DICOM SERVER AE Specification

This Application Entity provides Standard Conformance to the following DICOM V3.0 SOP Classes as an **SCU**:

SOP Class Name	SOP Class UID
Digital Mammography X-Ray Image Storage - For Presentation	1.2.840.10008.5.1.4.1.1.1.2
Digital Mammography X-Ray Image Storage - For Processing	1.2.840.10008.5.1.4.1.1.1.2.1
Secondary Capture Image Storage	1.2.840.10008.5.1.4.1.1.7
Study Root Query/Retrieve Information Model - FIND	1.2.840.10008.5.1.4.1.2.2.1
Study Root Query/Retrieve Information Model - MOVE	1.2.840.10008.5.1.4.1.2.2.2
Verification SOP Class	1.2.840.10008.1.1

Note: Verification SCU service is not accessible through user interface. You have to run the “sendecho” command from a command window.

Note: C-FIND is done using Study Root Information Model.

Note: C-MOVE is done using Study Root Information Model.

Note: Please also refer to sections 6 for Network Print Management SCU Conformance Statement.

This Application Entity provides Standard Conformance to the following DICOM V3.0 SOP Classes as an **SCP**:

SOP Class Name	SOP Class UID
Digital Mammography X-Ray Image Storage - For Presentation	1.2.840.10008.5.1.4.1.1.1.2
Digital Mammography X-Ray Image Storage - For Processing	1.2.840.10008.5.1.4.1.1.1.2.1
Secondary Capture Image Storage	1.2.840.10008.5.1.4.1.1.7
Verification SOP Class	1.2.840.10008.1.1

Note: Only Secondary Captures whose modality is MG, DX, CR or OT are supported.

Note: Other objects such as Digital X-ray images can be received but there are some limitations on the system working with such objects.

2.3.1.1 Association Establishment Policies

2.3.1.1.1 General

The DICOM Application Context Name (ACN), which is always proposed, is:

Application Context Name	1.2.840.10008.3.1.1.1
---------------------------------	------------------------------

The Maximum Length PDU negotiation is included in all association establishment requests.
The maximum length PDU for an association initiated by the DICOM SERVER AE is:

Maximum Length PDU	28Kbytes
---------------------------	-----------------

The SOP Class Extended Negotiation is not supported.

The maximum number of Presentation Context Items that will be proposed is 18

The user information Items sent by this product are:

- Maximum PDU Length
- Implementation UID

2.3.1.1.2 Number of Associations

The DICOM SERVER AE will initiate only one DICOM association at a time to perform a DICOM store operation as a SCU to a Remote Host AE.

The DICOM SERVER AE can have a maximum of 4 open DICOM associations at a time to perform a DICOM store operation as a SCP or respond to an echo.

The DICOM SERVER AE will initiate only one DICOM association at a time to perform a Query/Retrieve with a Remote Host AE.

2.3.1.1.3 Asynchronous Nature

Asynchronous mode is not supported. All operations will be performed synchronously.

2.3.1.1.4 Implementation Identifying Information

The Implementation UID for this DICOM v3.0 Implementation is:

SENOGRAPHE 2000 D Acquisition Workstation Implementation UID	1.2.840.113619.6.66
---	----------------------------

2.3.1.1.5 Association Initiation by Real-World Activity

2.3.1.1.5.1 Real-World Activity: Manual Transfer of Patients/Studies/Series/Images

2.3.1.1.5.1.1 Associated Real-World Activity

The operator does the following:

- They select in the BROWSER one or several Patient Folders (or Studies/Series/Images) to be sent. Then, they can either drag and drop the selection on the icon representing then Remote DICOM AE, or click on the “Push” icon and select a Remote DICOM AE in the LIST OF REMOTE HOST.

This operation will cause:

- The Senographe 2000 D Acquisition Workstation to retrieve the selected images from its local database.
- The DICOM SERVER AE to initiate a DICOM association, negotiate with the Remote AE an appropriate Abstract and Transfer Syntax.
- To emit C-STORE command to send the images, if the negotiation is successful.

2.3.1.1.5.1.2 Proposed Presentation Context Table

Presentation Context Table - Proposed					
Abstract Syntax		Transfer Syntax		Role	Extended Negotiation
Name	UID	Name List	UID List		
Digital Mammography X-Ray Image Storage - For Presentation	1.2.840.10008.5.1.4.1.1.1.2	Explicit VR Big Endian	1.2.840.10008.1.2.2	SCU	None
Digital Mammography X-Ray Image Storage - For Presentation	1.2.840.10008.5.1.4.1.1.1.2	Implicit VR Little Endian	1.2.840.10008.1.2	SCU	None
Digital Mammography X-Ray Image Storage - For Presentation	1.2.840.10008.5.1.4.1.1.1.2	Explicit VR Little Endian	1.2.840.10008.1.2.1	SCU	None
Digital Mammography X-Ray Image Storage - For Processing	1.2.840.10008.5.1.4.1.1.1.2.1	Explicit VR Big Endian	1.2.840.10008.1.2.2	SCU	None
Digital Mammography X-Ray Image Storage - For Processing	1.2.840.10008.5.1.4.1.1.1.2.1	Implicit VR Little Endian	1.2.840.10008.1.2	SCU	None
Digital Mammography X-Ray Image Storage - For Processing	1.2.840.10008.5.1.4.1.1.1.2.1	Explicit VR Little Endian	1.2.840.10008.1.2.1	SCU	None
Secondary Capture Image Storage	1.2.840.10008.5.1.4.1.1.7	Explicit VR Big Endian	1.2.840.10008.1.2.2	SCU	None
Secondary Capture Image Storage	1.2.840.10008.5.1.4.1.1.7	Implicit VR Little Endian	1.2.840.10008.1.2	SCU	None
Secondary Capture Image Storage	1.2.840.10008.5.1.4.1.1.7	Explicit VR Little Endian	1.2.840.10008.1.2.1	SCU	None

Note: Other presentation contexts not documented in this table could be proposed (e.g. Digital X-ray Image Storage/ Explicit VR Big Endian)

2.3.1.1.5.1.2.1 Common SOP Specific DICOM Conformance Statement for all Storage SOP Classes

Following are the status codes that are more specifically processed when receiving messages from a Storage SCP equipment:

Service Status	Status Codes	Further Meaning	Application Behavior When receiving Status Codes	Related Fields Processed if received
Refused	A7xx	Out of resources	Association is closed with Remote AE. A message is displayed to the user. Error is logged. Retry is done until 3 times.	(0000,0902)

	0122	SOP Class not Supported	Association is closed with Remote AE. A message is displayed to the user. Error is logged.	(0000,0902)
Error	Cxxx	Cannot Understand	Association is closed with Remote AE. A message is displayed to the user. Error is logged.	(0000,0901) (0000,0902)
	A9xx	Data Set does not match SOP Class	Association is closed with Remote AE. A message is displayed to the user. Error is logged.	(0000,0901) (0000,0902)
Warning	B000	Coercion of Data Elements	Association is closed with Remote AE. A message is displayed to the user. Error is logged.	(0000,0901) (0000,0902)
	B007	Data Set does not match SOP Class	Association is closed with Remote AE. A message is displayed to the user. Error is logged.	(0000,0901) (0000,0902)
	B006	Elements Discarded	Association is closed with Remote AE. A message is displayed to the user. Error is logged.	(0000,0901) (0000,0902)
Success	0000			None

2.3.1.1.5.2 Real-World Activity: Automatic Transfer of Patients/Studies/Series/Images

2.3.1.1.5.2.1 Associated Real-World Activity

The operator does the following:

- They set Auto-Push ON and Auto-Push remote hosts.
- They start an exam, acquire images and close the exam.

This operation will cause:

- The DICOM SERVER AE to initiate a DICOM association, negotiate with the Remote AE an appropriate Abstract and Transfer Syntax.
- To emit C-STORE command to send the acquired images, if the negotiation is successful.

2.3.1.1.5.2.2 Proposed Presentation Context Table

Same as in the Real World Activity “Manual Transfer of Patients/Studies/Series/Images”.

2.3.1.1.5.2.2.1 Common SOP Specific DICOM Conformance Statement for all Storage SOP Classes

Same as in the Real World Activity “Manual Transfer of Patients/Studies/Series/Images”.

2.3.1.1.5.3 Real-World Activity: Manual Query/Retrieve

2.3.1.1.5.3.1 Associated Real-World Activity

The operator queries a Remote database by clicking on the icon representing the DICOM Remote AE. A new BROWSER (known as the REMOTE BROWSER) appears on the screen(s) upon successful query. Then, the operator can select one or several Patient Folders/Studies/Series/Images and can either drag on drop the selection on the icon representing the SENOGRAPHE 2000 D Acquisition Workstation or click on the “Pull” icon to retrieve the selection on the SENOGRAPHE 2000 D Acquisition Workstation database.

- These operation will cause:
- the DICOM SERVER AE to initiate a DICOM association.

- the DICOM SERVER AE to emit a C-FIND request to get a list of patients regarding the criteria listed below, then to get the selected studies, series or images.
- the DICOM SERVER AE to emit a C-MOVE request to specify a selected list of Patient Folders/Studies/Series/Images to be sent by the Remote Host to the SENOGAPHE 2000 D Acquisition Workstation.

2.3.1.1.5.3.2 Proposed Presentation Context Table

Presentation Context Table - Proposed					
Abstract Syntax		Transfer Syntax		Role	Extended Negotiation
Name	UID	Name List	UID List		
Study Root Query/Retrieve Information Model - FIND	1.2.840.10008.5.1.4.1.2.2.1	Implicit VR Little Endian	1.2.840.10008.1.2	SCU	None
Study Root Query/Retrieve Information Model - MOVE	1.2.840.10008.5.1.4.1.2.2.2	Implicit VR Little Endian	1.2.840.10008.1.2	SCU	None

2.3.1.1.5.3.2.1 SOP Specific DICOM Conformance Statement for the Model, Study Root Query/Retrieve Information Model -FIND SOP Class

Following are the status codes that are more specifically processed when receiving messages from a Query SCP equipment:

Service Status	Status Codes	Further Meaning	Application Behavior When receiving Status Codes	Related Fields Processed if received
Refused	A7xx	Out of resources	Association is closed. Appropriate message is displayed to the user.	(0000,0902)
	0122	SOP Class not Supported	Association is closed. Appropriate message is displayed to the user.	(0000,0902)
Failed	A9xx	Identifier does not match SOP Class	Association is closed. Error message is displayed to the user.	(0000,0901) (0000,0902)
	Cxxx	Unable to process	Association is closed. Error message is displayed to the user.	(0000,0901) (0000,0902)
Cancel	FE00	Matching terminated due to cancel	Association is closed. Error message is displayed to the user.	None
Success	0000	Matching is complete - No final identifier is supplied		None
Pending	FF00	Matches are continuing - Current Match is supplied and any Optional Keys		Identifier

		were supported in the same manner as Required Keys.		
	FF01	Matches are continuing - Warning that one or more Optional Keys were not supported for existence and/or matching for this Identifier		Identifier

Note: Status code Cancel is considered as an error because it should never be received as the user can't ask for a cancel.

The C-FIND SCU will only perform hierarchical query (No extended negotiation supported)
Each C-FIND SCU supports an "Association Timer", "Operation Timer", "Session Timer" that can be configured at installation time. These timers are defaulted to 60, 90, 3600 seconds.
The DICOM SERVER AE will parse each matching C-FIND-RSP reply and will abort the association if an entry does not contain a valid dataset.

2.3.1.1.6 Association Acceptance Policy

When the DICOM SERVER AE accepts an association, it will receive any images transmitted on that association and store the supported SOP Classes on disk. Any Remote DICOM AE can send images to the DICOM SERVER AE.

2.3.1.1.6.1 Real-World Activity "Image Installation"

The DICOM SERVER AE accepts an association when it receives a valid association request from a DICOM Storage SCU.

2.3.1.1.6.1.1 Associated Real-World Activity

The DICOM SERVER AE waits for any association. No operator action is required to receive an image.

2.3.1.1.6.1.2 Accepted Presentation Context Table

Presentation Context Table - Accepted					
Abstract Syntax		Transfer Syntax		Role	Extended Negotiation
Name	UID	Name List	UID List		
Digital Mammography X-Ray Image Storage - For Presentation	1.2.840.10008.5.1.4.1.1.1.2	Implicit VR Little Endian	1.2.840.10008.1.2	SCP	None
Digital Mammography X-Ray Image Storage - For Processing	1.2.840.10008.5.1.4.1.1.1.2.1	Implicit VR Little Endian	1.2.840.10008.1.2	SCP	None
Secondary Capture Image Storage	1.2.840.10008.5.1.4.1.1.7	Implicit VR Little Endian	1.2.840.10008.1.2	SCP	None
Verification SOP Class	1.2.840.10008.1.1	Implicit VR Little Endian	1.2.840.10008.1.2	SCP	None

Note: Other presentation context not documented in this table could be accepted (e.g. Digital X-Ray /Implicit VR Little Endian) but there are some limitations on the system working with such images.

2.3.1.1.6.1.2.1 SOP Specific DICOM Conformance Statement for all Storage SOP Classes

Following are the status codes the Application may send back to the SCU Equipment after performing the requested Storage:

Service Status	Status Codes	Further Meaning	Status Code sending explanation	Related Fields sent back to the SCU
Refused	A7xx	Out of resources	indicates that there was not enough space or some other internal resource (such as memory) to store the image. The user should attempt recovery by removing some images from the SENOGRAPHE 2000 D Acquisition Workstation	(0000,0902)
Error	0110	Processing Failure	indicates that an internal system call has failed while processing the image.	(0000,0902)
Success	0000			None

Each C-STORE SCP supports an “Association Timer”, “Operation Timer”, “Session Timer” that can be configured at installation time. These timers are defaulted to 60, 180, 3600 seconds.

The DICOM Server AE conforms to the SOP’s of the Storage Service Class at Level 2 (Full) as described in Section B4.1 of PS 3.4 of the DICOM Standard Document.

Image Reception phase:

- If the DICOM Server AE fails to parse the received image, the error 110 (Processing Failure) is returned to the C-STORE SCU.
- If the DICOM Server AE fails to install the received image into the local database, the error A700 (Out of Resources) is returned to the C-STORE SCU.

When a C-STORE operation is returned Successful to the C-STORE SCU, the image has been written to the disk and declared into the local database. The image will then be accessed in the same manner as any other image by the applications on the SENOGRAPHE 2000 D Acquisition Workstation.

When a C-STORE operation is returned Error to the C-STORE SCU, the image will be removed and a message will appear in the browser message log informing the user of a failure.

2.3.1.1.6.1.3 Presentation Context Acceptance Criterion

Only known SOP Classes are accepted.

2.3.1.1.6.1.4 Transfer Syntax Selection Policies

The default transfer syntax for SOP Classes is always Implicit VR Little Endian: (1.2.840.10008.1.2).

2.3.2 WORKLIST SERVER AE Specification

This Application Entity provides Standard Conformance to the following DICOM V3.0 SOP Classes as a SCU:

SOP Class Name	SOP Class UID
Modality Worklist Information Model - FIND	1.2.840.10008.5.1.4.31

2.3.2.1 Association Establishment Policies

2.3.2.1.1 General

The DICOM Application Context Name (ACN), which is always proposed, is:

Application Context Name	1.2.840.10008.3.1.1.1
---------------------------------	------------------------------

The Maximum Length PDU negotiation is included in all association establishment requests.
The maximum length PDU for an association initiated by the WORKLIST SERVER AE is:

Maximum Length PDU	28Kbytes
---------------------------	-----------------

The SOP Class Extended Negotiation is not supported.
The maximum number of Presentation Context Items that will be proposed is 1
The user information Items sent by this product are:

- Maximum PDU Length
- Implementation UID

2.3.2.1.2 Number of Associations

The WORKLIST SERVER AE (SCU) will initiate only one DICOM association at a time to perform a modality worklist query of a single remote AE.

2.3.2.1.3 Asynchronous Nature

Asynchronous mode is not supported. All operations will be performed synchronously.

2.3.2.1.4 Implementation Identifying Information

The Implementation UID for this DICOM v3.0 Implementation is:

SENOGRAPHE 2000 D Acquisition Workstation Implementation UID	1.2.840.113619.6.66
---	----------------------------

2.3.2.1.5 Association Initiation by Real-World Activity

2.3.2.1.5.1 Real-World Activity: Worklist Query

2.3.2.1.5.1.1 Associated Real-World Activity

The operator of the system initiates a query for a modality worklist by pressing the REFRESH WORKLIST button of the Worklist screen. The Worklist Server will then initiate an association with the remote AE in order to query for the worklist

A user can configure a number of parameters which directly control the worklist query request. The user can request worklist items that are intended for the system the user is working at, all items that apply to the modality of the system the user is working at or all worklist items available. These selections and their affects on worklist query parameters are given below:

This System:

- Modality, (0008,0060) - set to MG
- Scheduled Station AE Title, (0040,0001) - set to Query AE title

The Query AE Title is defined in the Query section of the Worklist Configuration file:
~sdc/senovision/config/WorklistCfg.cfg

This Modality:

- Modality, (0008,0060) - set to MG
- Scheduled Station AE Title, (0040,0001) - zero-length (universal matching)

All Systems:

- Modality, (0008,0060) - zero-length (universal matching)
 - Scheduled Station AE Title, (0040,0001) - zero-length (universal matching)
- The scheduled dates of procedures of interest can be specified for query by selecting a specific date range. The date ranges available are Today, Tomorrow or between two given dates. These selections and their affects on worklist query parameters are given below:

Today:

Scheduled Procedure Step Start Date, (0040,0002) - set to YYYYMMDD-YYYYMMDD, where YYYYMMDD is the current date.

Tomorrow:

Scheduled Procedure Step Start Date, (0040,0002) - set to YYYYMMDD-YYYYMMDD, where YYYYMMDD is tomorrow date.

Between 2 dates:

Scheduled Procedure Step Start Date, (0040,0002) - set to YYYYMMDD-YYYYMMDD', where YYYYMMDD is set to given From date and YYYYMMDD' is set to given To date.

Patient Name:

Patient Name, (0010,0010) - set to given Patient Name

Patient ID:

Patient ID, (0010,0020) - set to given Patient ID

2.3.2.1.5.1.2 Proposed Presentation Context Table

The following table shows the proposed presentation contexts for the Worklist Server AE after real-world activity "Worklist Query" has been initiated:

Presentation Context Table - Proposed					
Abstract Syntax		Transfer Syntax		Role	Extended
Name	UID	Name List	UID List		Negotiation
Modality Worklist Information Model - FIND	1.2.840.10008.5.1.4.31	Implicit VR Little Endian	1.2.840.10008.1.2	SCU	None

2.3.2.1.5.1.2.1 SOP Specific DICOM Conformance Statement for the Worklist SOP Class

Following are the status codes that are more specifically processed when receiving messages from a **Modality Worklist SCP** equipment:

If the remote AE does not support the proposed Presentation Context, an appropriate error is logged and the operator is notified.

This implementation can receive multiple C-FIND results over a single association. Only one association is opened at a time.

Each C-FIND response received from the remote AE is parsed to verify the length/type of the items in the response. Upon detecting any error in the response data, the Worklist Server AE will ignore the bad data and carry on to the next C-FIND response.

On receipt of any error from the remote AE, the Worklist Server will issue a C-FIND-CANCEL and, upon receipt of a C-FIND-RSP (or if an applicable timer expires), will abort the association. Warnings received from the remote AE are ignored.

Each C-FIND operation supports a configurable “Association Timer.” This timer starts when the association request is sent or received and stops when the association is established. The default time-out value is 30 seconds.

Each C-FIND operation supports a configurable “Session Timer.” This timer starts when an association is established and stops when the association is ended. The default time-out value is 3600 seconds.

If any of the above timers expires, the association is aborted (A-ABORT) and the operation in progress is considered to be failed. Any previously received worklist items are kept.

2.3.2.1.5.1.2.2 Record Acceptance Policy

All worklist items coming from the remote AE are accepted. Nevertheless, the system filters each received worklist item checking that it matches the query parameters. If the received worklist item matches the query parameter, then it is stored in the local Worklist database and displayed to the user, else it is ignored.

The filter checks the following fields:

Tag Value	Worklist Attribute	Acceptance
0008.0005	Specific Character Set	Check that value is empty or equal to ISO_IR 100
0008.0060	Modality	Check that value is empty or equal to MG
0040.0001	Scheduled Station AE Title	If matching is defined in the query parameters, then check that value is empty or equal to the defined value in query parameters setting.
0040.0002	Scheduled Procedure Step Start Date	If matching is defined in the query parameters, then check that value is empty or equal to the defined value in query parameters setting.
0010.0010	Patient Name	If value defined in Query Definition Window, check that value matches the defined value
0010.0020	Patient ID	If value defined in Query Definition Window, check that value matches the defined value

2.3.2.2 Association Acceptance Policy

The Worklist Server AE does not respond to attempts by a remote AE to open an association.

2.3.3 STORAGE COMMITMENT SERVER AE Specification

This Application Entity provides Standard Conformance to the following DICOM V3.0 SOP Classes as a SCU:

SOP Class Name	SOP Class UID
Storage Commitment Push Model	1.2.840.10008.1.20.1

2.3.3.1 Association Establishment Policies

2.3.3.1.1 General

The DICOM Application Context Name (ACN), which is always proposed, is:

Application Context Name	1.2.840.10008.3.1.1.1
---------------------------------	------------------------------

The Maximum Length PDU negotiation is included in all association establishment requests. The maximum length PDU for an association initiated by the STORAGE COMMITMENT SERVER AE is:

Maximum Length PDU	28Kbytes
---------------------------	-----------------

The SOP Class Extended Negotiation is not supported. The maximum number of Presentation Context Items that will be proposed is 1. The user information Items sent by this product are:

- Maximum PDU Length
- Implementation UID

2.3.3.1.2 Number of Associations

The STORAGE COMMITMENT SERVER AE will initiate only one DICOM association at a time to perform a DICOM storage commitment operation as a SCU to a Remote Host AE.

2.3.3.1.3 Asynchronous Nature

Asynchronous mode is not supported. All operations will be performed synchronously.

2.3.3.1.4 Implementation Identifying Information

The Implementation UID for this DICOM v3.0 Implementation is:

SENOGRAPHE 2000 D Acquisition Workstation Implementation UID	1.2.840.113619.6.66
---	----------------------------

2.3.3.1.5 Association Initiation by Real-World Activity

2.3.3.1.5.1 Real-World Activity: “Images successfully sent to a remote host declared as a Storage Commitment Provider”

2.3.3.1.5.1.1 Associated Real-World Activity

The operator or GE Field Engineer can declare a Remote Host as Storage Commitment Provider on the SENOGRAPHE 2000 D Acquisition Workstation. The operator selects in the BROWSER one or several Patient Folders (or Studies/Series/Images) to be sent. Then, the user can either drag and drop the selection on the icon representing then Remote DICOM AE, or click on the “Push” icon and select a Remote DICOM AE in the LIST OF REMOTE HOST. The selected Remote DICOM AE must be declared as Storage Commitment Provider. This operation will cause:

- The SENOGRAPHE 2000 D Acquisition Workstation to retrieve the selected image from its local database.
- The DICOM SERVER AE to initiate a DICOM association, negotiate with the Remote AE an appropriate Abstract and Transfer Syntax.
- To emit C-STORE command to send the image, if the negotiation is successful.

- When all images have been successfully sent, the DICOM SERVER AE asks the STORAGE COMMITMENT SERVER AE to commit the images.
- The STORAGE COMMITMENT SERVER AE initiates a DICOM association, negotiate with the Remote AE an appropriate Abstract and Transfer Syntax.
- If the negotiation is successful, STORAGE COMMITMENT SERVER AE emits a N-ACTION request. Only one N-ACTION Request is sent for all images to be committed.

2.3.3.1.5.1.2 Proposed Presentation Context Table

Presentation Context Table - Proposed					
Abstract Syntax		Transfer Syntax		Role	Extended Negotiation
Name	UID	Name List	UID List		
Storage Commitment Push Model	1.2.840.10008.1.20.1	Explicit VR Big Endian	1.2.840.10008.1.2.2	SCU	None
Storage Commitment Push Model	1.2.840.10008.1.20.1	Implicit VR Little Endian	1.2.840.10008.1.2	SCU	None
Storage Commitment Push Model	1.2.840.10008.1.20.1	Explicit VR Little Endian	1.2.840.10008.1.2.1	SCU	None

2.3.3.1.5.1.2.1 SOP Specific DICOM Conformance Statement for the Storage Commitment Push Model SOP Class

If the association negotiation is not successful the STORAGE COMMITMENT SERVER AE retries the association negotiation 3 times. After the 3 retries, if association negotiation still fails, an error file is logged, the Storage Commitment is abandoned and a pop-up is displayed to the user.

After the N-ACTION request, if the received N-ACTION Response from the Storage Commitment Provider has a failure status, an error file is logged, the Storage Commitment is abandoned and a pop-up is displayed to the user.

After the N-ACTION request, if the received N-ACTION Response from the Storage Commitment Provider has a success status, the STORAGE COMMITMENT SERVER AE can receive the N-EVENT-REPORT from the Storage Commitment Provider at any time (See section *Real-World Activity “Image Remotely Committed”*) There is no time out to limit the period of time between the reception of the N-ACTION Response and the reception of the N-EVENT-REPORT from the Storage Commitment Provider.

2.3.3.1.6 Association Acceptance Policy

The STORAGE COMMITMENT SERVER AE accepts an association for Storage Commitment notification (N-EVENT-REPORT) **only as a SCU**. The Storage Commitment Provider initiating the association must use the role selection negotiation.

2.3.3.1.6.1 Real-World Activity “Image Remotely Committed”

The STORAGE COMMITMENT SERVER AE accepts an association when it receives a valid association request from a STORAGE COMMITMENT Provider.

2.3.3.1.6.1.1 Associated Real-World Activity

The STORAGE COMMITMENT SERVER AE waits for any association. No operator action is required to receive a storage commitment notification.

2.3.3.1.6.1.2 Accepted Presentation Context Table

Presentation Context Table - Accepted					
Abstract Syntax		Transfer Syntax		Role	Extended
Name	UID	Name List	UID List		Negotiation
Storage Commitment Push Model	1.2.840.10008.1.20.1	Explicit VR Big Endian	1.2.840.10008.1.2.2	SCP	None
Storage Commitment Push Model	1.2.840.10008.1.20.1	Implicit VR Little Endian	1.2.840.10008.1.2	SCP	None
Storage Commitment Push Model	1.2.840.10008.1.20.1	Explicit VR Little Endian	1.2.840.10008.1.2.1	SCP	None

Note: The Storage Commitment Provider initiating the association must use the role selection negotiation.

2.3.3.1.6.1.2.1 SOP Specific DICOM Conformance Statement for all Storage SOP Classes

Following are the status codes the Application may send back to the SCP Equipment after receiving the N-EVENT-REPORT:

Service Status	Status Codes	Further Meaning	Status Code sending explanation	Related Fields sent back to the SCP
Error	0110	Processing Failure	indicates that an internal system call has failed while processing the storage commitment notification	None
Success	0000			None

Storage Commitment Notification notify the STORAGE COMMITMENT SERVER AE if the Storage Commitment Provider has successfully committed the images or not.

If an image has been successfully committed, the STORAGE COMMITMENT SERVER AE asks the local database to flag the image as “Committed”.

If an image has NOT been committed, the STORAGE COMMITMENT SERVER AE logs the error file and displays a pop-up to the user.

If the STORAGE COMMITMENT SERVER AE has successfully processed the notification as described above, Success is sent back to the Storage Commitment Provider else Error.

2.3.3.1.6.1.3 Presentation Context Acceptance Criterion

The Storage Commitment Provider initiating the association must use the role selection negotiation

2.3.3.1.6.1.4 Transfer Syntax Selection Policies

Explicit Big Endian transfer syntax is chosen first, then the Explicit Little Endian and then the Implicit Little Endian.

2.4 COMMUNICATION PROFILES

2.4.1 Supported Communication Stacks (PS 3.8, PS 3.9)

DICOM Upper Layer (PS 3.8) is supported using TCP/IP.

GE HEALTHCARE
2246811-2-1EN REV 1

2.4.2 OSI Stack

OSI stack not supported

2.4.2.1 Physical Media Support

Not Applicable.

2.4.3 TCP/IP Stack

The TCP/IP stack is inherited from a UNIX Operating System.

2.4.3.1 API

Not applicable to this product.

2.4.3.2 Physical Media Support

DICOM is indifferent to the Physical medium over which TCP/IP executes (e.g. Ethernet V2.0, IEEE 802.3, ATM, FDDI)

For more information about the Physical Media available on SENOGAPHE 2000 D Acquisition Workstation, please refer to the Product Data Sheet.

2.4.4 Point-to-Point Stack

A 50-pin ACR-NEMA connection is not applicable to this product.

2.5 EXTENSIONS / SPECIALIZATIONS / PRIVATIZATIONS

2.5.1 Standard Extended /Specialized/Private SOPs

None supported

2.5.2 Private Transfer Syntaxes

None supported

2.6 CONFIGURATION

2.6.1 AE Title/Presentation Address Mapping

DICOM SERVER AE:

AE Title is set to "hostname".

WORKLIST SERVER AE:

AE Title is set to "WL_hostname".

STORAGE COMMITMENT SERVER AE:

AE Title is set to "SCU_hostname".

"hostname" is system hostname and it is configured by a GE Field Engineer during installation.

2.6.2 Configurable Parameters

The following fields are configurable for this AE (local):

- Local IP Address
- Local IP Netmask

The Local Listening Port Number for C-STORE SCP DICOM service is not configurable and set to **4006**

The Local Listening Port Number for STORAGE COMMITMENT DICOM service is not configurable and set to **4008**

The following fields are configurable for every remote DICOM AE including Worklist provider:

- Remote AE Title
- Remote IP Address
- Listening TCP/IP Port Number

Only one **default router** IP Address can be configured for **all remote nodes**.

The following fields are configurable:

- Association Establishment Timer
- Store, Find, Move, Timers
- Inactivity Timers
- Maximum Length PDU

2.7 SUPPORT OF EXTENDED CHARACTER SETS

The SENOGRAPHE 2000 D Acquisition Workstation will support only the ISO_IR 100 (ISO 8859-1:1987 Latin alphabet N 1. supplementary set) as extended character sets.

THIS PAGE LEFT INTENTIONALLY BLANK

3. MEDIA STORAGE CONFORMANCE STATEMENT

3.1 INTRODUCTION

This section of the conformance statement (CS) specifies the SENOGRAPHE 2000 D Acquisition Workstation compliance to DICOM Media Interchange. It details the DICOM Media Storage Application Profiles and roles which are supported by this product.

This station provides capabilities to DICOM interchange on CD-Rs (Compact Disc-Recordable), and on CDROMs (Compact Disc Read Only Memory). The SENOGRAPHE 2000 D Acquisition Workstation works with Digital Mammography X-Ray (MG) For Processing, and Digital Mammography X-Ray (MG) For Presentation images.

Note that the format of this section strictly follows the format defined in DICOM Standard PS 3.2 (Conformance). Please refer to that part of the standard while reading this section.

3.2 IMPLEMENTATION MODEL

3.2.1 Application Data Flow Diagram

The Basic and Specific Application models for the CDR device and the CDROM device are shown in the following Illustrations:

SPECIFIC AE APPLICATION MODEL FOR THE CDR DEVICE

- Description of the data Flow Diagram for the CD-R device.

The DICOM ARCHIVE/RESTORE functionality for the CD-R device is handled by the CD-R/CDROM DICOM Media Server Application Entity (AE). The CD-R/CDROM DICOM Media Server Application Entity (AE) is commanded by the user to perform DICOM services operating on the DICOM media through the use of buttons and menu selections on the graphical user interface of the station.

The user requests the creation of a DICOM file set and the writing of this DICOM File Set on a blank CD-R by selecting images in the local Browser, and by a drag and drop of those images on the CD-R icon Images are saved on a mono-session disk in a one shot operation.

The user can request the reading of a DICOM file set written on a CDROM by selecting the CD-R drive as the active archive device, and browsing the archive using the "Query" Item of the Archive drop down menu, and then restore the selected items by a drag and drop on the local browser icon or by clicking on the suitable restore buttons.

The Application models for the CDR device are shown in Illustration 0-1.

ILLUSTRATION 0-1
SPECIFIC AE APPLICATION MODEL

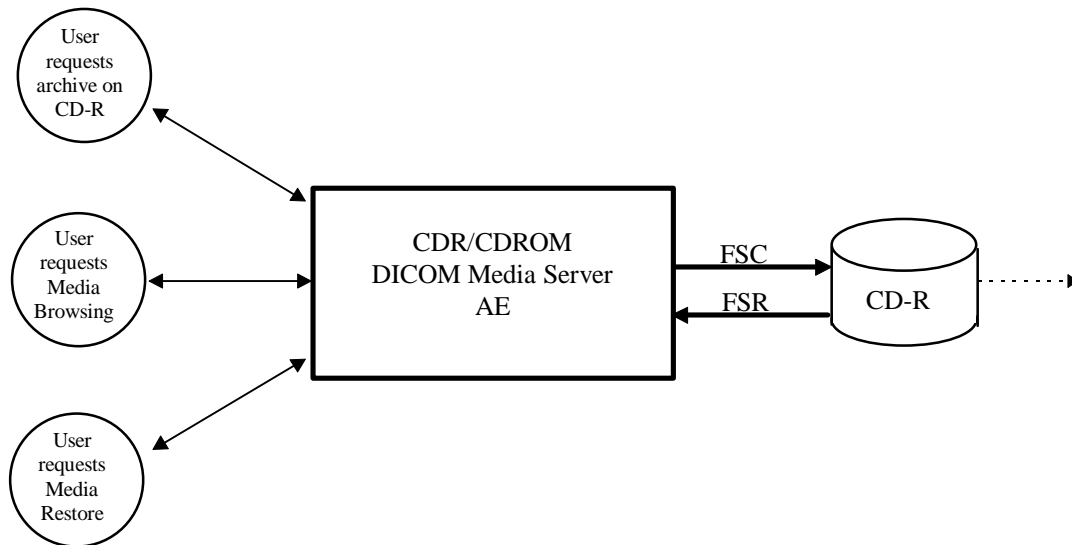

- Description of the data Flow Diagram for the CDROM device.

The DICOM ARCHIVE/RESTORE functionality for the CDROM device is handled by the CD-R/CDROM DICOM Media Server Application Entity (AE). The CD-R/CDROM DICOM Media Server Application Entity (AE) is commanded by the user to perform DICOM services operating on the DICOM media through the use of buttons and menu selections on the graphical user interface of the station.

The user can request the reading of a DICOM file set written on a CDROM by selecting the CD-R drive as the active archive device, and browsing the archive using the "Query" Item of the Archive drop down menu, and then restore the selected items by a drag and drop on the local browser icon or by clicking on the suitable restore buttons.

The Application model for the CDR/CDROM device are shown in Illustration 3-2

ILLUSTRATION 0-2

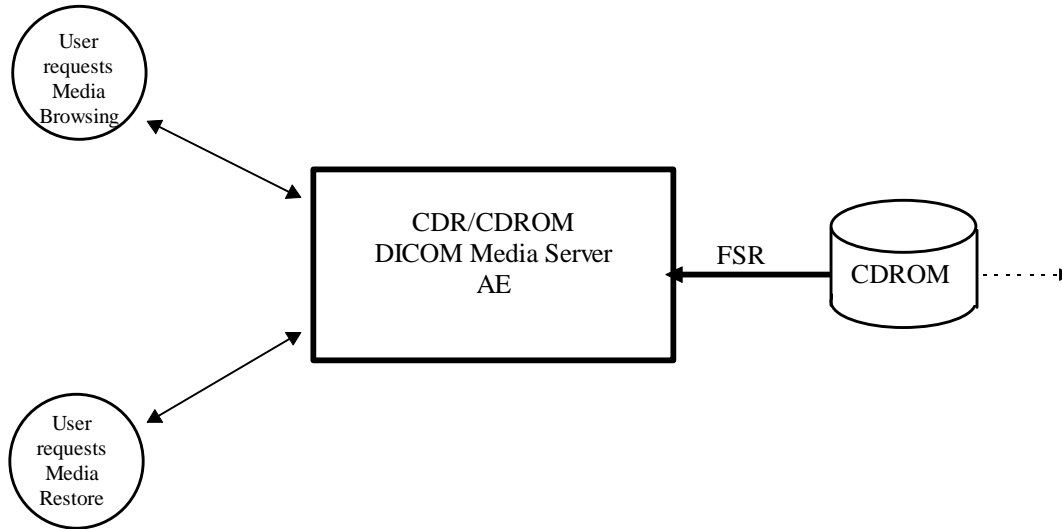

3.2.2 Functional Definition of AE's

3.2.2.1 Functional Definition of the DICOM Media Server AE

3.2.2.1.1 Functional definition of the CDR/CDROM DICOM Media Server AE

The CDR/CDROM DICOM Media Server Application Entity supports the following functions:

- Has access to patient demographics and pixel data in the local database.
- Can generate a DICOM File Set (FSC) for Digital Mammography X-Ray (MG) For Processing and MG For Presentation data types in a one shot activity.
- Can write a DICOM File Set (FSC) on a CD-R in mono-session.
- Can read a DICOM File Set (FSR) on a CD-R/CDROM.

3.2.3 Sequencing Requirements

Non Applicable for writing a CD-R.

For restoring images from a CD-R/CD-ROM:

1. Browse the CD-R/CD-ROM
2. User selects images to be restored from CD-R/CD-ROM to the system.
3. System restores Images.

3.2.4 File Meta Information Options (See PS3.10)

The File Meta-Information for this implementation is:

File Meta-Information Version	1
SENOGRAPHE 2000 D Acquisition Workstation Implementation UID	1.2.840.113619.6.66
Implementation Version Name	The Implementation Version Name is set dynamically through an environment variable

3.3 AE SPECIFICATIONS

3.3.1 DICOM CDR/CDROM SERVER AE Specification

The DICOM CDR/CDROM SERVER Application Entity provides standard conformance to DICOM Interchange Option of the Media Storage Service Class. The application Profiles and roles are listed below.

Supported Application Profile	Real World Activity	Role	Description
STD-GEN-CD	Browse CD	FSR	Interchange
STD-GEN-CD	Restore CD	FSR	Interchange
STD-GEN-CD	Archive CD	FSC See Note	Interchange

Archive is available only on blank CD-Rs.

Browse and Restore is possible on CD-R and CD-ROM

3.3.1.1 File Meta Information for the DICOM CDR/CDROM Application Entity

Following are the values set in the File Meta Information for this AE Title:

Source Application Entity Title	Set to system hostname
--	-------------------------------

3.3.1.2 Real-World Activities for the DICOM CDR/CDROM Application Entity

3.3.1.2.1 Real-World Activity (RWA) "Browse CD"

The CD-R/CDROM DICOM Media Server AE acts as an FSR using the interchange option when requested to browse the CD.

When the CD-R/CDROM DICOM Media Server AE is requested to provide a directory listing, it reads the File-set and displays the DICOMDIR directory entries, according to the PATIENT, STUDY, SERIES, IMAGE paradigm.

If the DICOMDIR file is not found in the File-set, the CD is ejected out of the drive.

3.3.1.2.1.1 Media Storage Application Profile for the RWA "Browse CD":

For the list of Application Profiles that invoke this AE for the Browse CD RWA, see the Table in Section 0

3.3.1.2.1.1.1 Options:

Following are the SOP Classes supported by the RWA "Browse CD":

Information Object Definition	SOP Class UID	Transfer Syntax	Transfer Syntax UID
Media Storage Directory Storage	1.2.840.10008.1.3.10	Explicit VR Little Endian	1.2.840.10008.1.2.1

3.3.1.2.2 Real-World Activity (RWA) "Restore CD"

The CD-R/CDROM DICOM Media Server AE acts as an FSR using the interchange option when requested to copy SOP instances from the CD to the local database.

The user selects the SOP instances that he wants the DICOM Media Server AE to copy on the local data base by a drag and drop on the local browser icon or or by clicking on the suitable restore buttons. Once selected, the SOP instances are copied from the media to the local database.

Only, the SOP classes supported by the station are declared to the database in a transfer syntax supported by the station.

3.3.1.2.2.1 Media Storage Application Profile for the RWA “Restore CD”:

For the list of Application Profiles that invoke this AE for the Restore CD RWA, see the Table in Section 0.

3.3.1.2.2.1.1 Options:

Following are the SOP Classes supported by the RWA “Restore CD”:

Information Object Definition	SOP Class UID	Transfer Syntax	Transfer Syntax UID
Media Storage Directory Storage	1.2.840.10008.1.3.10	Explicit VR Little Endian	1.2.840.10008.1.2.1
Digital Mammography Xray For Processing Image Storage	1.2.840.10008.5.1.4.1.1.1.2.1	Explicit VR Little Endian	1.2.840.10008.1.2.1
Digital Mammography Xray for Presentation Image Storage	1.2.840.10008.5.1.4.1.1.1.2	Explicit VR Little Endian	1.2.840.10008.1.2.1
Secondary Capture Image Storage	1.2.840.10008.5.1.4.1.1.7	Explicit VR Little Endian	1.2.840.10008.1.2.1

Note: Only Secondary Captures whose modality is MG, DX, CR or OT are supported

Note: Other objects such as Digital Xray Images can be restored but there are some limitations on the system working with such objects.

3.3.1.2.3 Real-World Activity (RWA) ”Archive CD”

The CD-R/CDROM DICOM Media Server acts as an FSC using the interchange option when requested to copy SOP Instances from the local data base to the CD-R.

The user has to insert a blank CD into the CD-R drive. Then, the user selects the entries in the local database that he wants the CD-R/CDROM DICOM Media Server to copy onto the CD.

A confirmation pop-up that indicates what can be archived on the CD-R is displayed.

Before writing the CD, the DICOM Media Server checks for the following conditions:

- The inserted media is blank and writable. If the condition is not met, an error is displayed and the CD is ejected.
- The corresponding SOP instances have been encoded with the ISO_IR 100 Specific Character Set or DICOM Default Character Set.

The corresponding SOP instances are set to the transfer syntax defined by the application and copied to the CD. Unknown Private Data Elements are coded as “UN” for Unknown.

3.3.1.2.3.1 Media Storage Application Profile for the RWA “Archive CD”:

Please refer to the Table in Section 0.

3.3.1.2.3.1.1 Options:

Following are the SOP Classes supported by the RWA “Archive CD”:

Information Object Definition	SOP Class UID	Transfer Syntax	Transfer Syntax UID
Media Storage Directory Storage	1.2.840.10008.1.3.10	Explicit VR Little Endian	1.2.840.10008.1.2.1
Digital Mammography Xray For Processing Image Storage	1.2.840.10008.5.1.4.1.1.1.2.1	Explicit VR Little Endian	1.2.840.10008.1.2.1
Digital Mammography Xray For Presentation Image Storage	1.2.840.10008.5.1.4.1.1.1.2	Explicit VR Little Endian	1.2.840.10008.1.2.1

Secondary Capture Image Storage	1.2.840.10008.5.1.4.1.1 .7	Explicit VR Little Endian	1.2.840.10008.1.2.1
---------------------------------	-------------------------------	---------------------------	---------------------

3.4 AUGMENTED AND PRIVATE APPLICATION PROFILES

No augmented/private profile is implemented

3.5 EXTENSIONS, SPECIALIZATIONS, PRIVATIZATIONS OF SOP CLASSES AND TRANSFER SYNTAXES

3.5.1 Extensions, Specializations, and Privatizations of SOP Classes

3.5.1.1 SOP Specific Conformance Statement for SOP Media Storage Directory

The following keys are added as Type 3 data elements in the Basic Directory IOD:

Key Attribute	Tag	Directory Record Type
Patient's Birth Date	(0010,0030)	PATIENT
Patient's Sex	(0010,0040)	PATIENT
Series Description	(0008,103E)	SERIES
Manufacturer	(0008,1090)	SERIES
Institution Name	(0008,0080)	SERIES
Institution Address	(0008,0081)	SERIES
Attending Physician's Name	(0008,1050)	SERIES
Image Type	(0008,0008)	IMAGE
Rows	(0028,0010)	IMAGE
Columns	(0028,0011)	IMAGE
Body Part Examined	(0018,0015)	IMAGE
Acquisition Device Processing Description	(0018,1400)	IMAGE
Image Laterality	(0020,0062)	IMAGE

Note: The CD-ROM Browser displays less information than the local Browser.

3.5.2 Private Transfer Syntax Specification

No private Transfer Syntax is written on media by the described DICOM CDR/CDROM SERVER AE of SENOGAPHE 2000 D Acquisition Workstation.

3.6 CONFIGURATION

The source AE Title encoded in the File Meta-Information can not be modified.

3.7 SUPPORT OF EXTENDED CHARACTER SETS

The SENOGAPHE 2000 D Acquisition Workstation will support only the ISO_IR 100 (ISO 8859-1:1987 Latin alphabet N 1. supplementary set) as extended character sets. Any incoming SOP instance that is encoded using another extended character set will not be installed in the local database.

4. DIGITAL MAMMOGRAPHY X-RAY INFORMATION OBJECT IMPLEMENTATION

4.1 INTRODUCTION

This section specifies the use of the DICOM Digital Mammography X-ray (MG) Image IOD to represent the information included in MG images produced by this implementation. Corresponding attributes are conveyed using the module construct. The contents of this section are:

0 - IOD Description

0 - IOD Entity-Relationship Model

0 - IOD Module Table

0- IOD Module Definition

4.2 MG IOD IMPLEMENTATION

The MG Image IOD is used in two SOP classes as defined in PS3.4 Storage Service Class, a SOP Class for storage of images intended for presentation, and a SOP class for storage of images intended for further processing before presentation. These are distinguished by their SOP Class UID and by the Enumerated Value of the mandatory Attribute in DX Series Module, Presentation Intent Type (0008,0068).

4.3 MG ENTITY-RELATIONSHIP MODEL

The Entity-Relationship diagram for the MG Image interoperability schema is shown in Illustration 0-1. In this figure, the following diagrammatic convention is established to represent the information organization:

- each entity is represented by a rectangular box
- each relationship is represented by a diamond shaped box.
- the fact that a relationship exists between two entities is depicted by lines connecting the corresponding entity boxes to the relationship boxes.

The relationships are fully defined with the maximum number of possible entities in the relationship shown. In other words, the relationship between Series and Image can have up to n Images per Series, but the Patient to Study relationship has 1 Study for each Patient (a Patient can have more than one Study on the system, however each Study will contain all of the information pertaining to that Patient).

ILLUSTRATION 0-1
MG IMAGE ENTITY RELATIONSHIP DIAGRAM

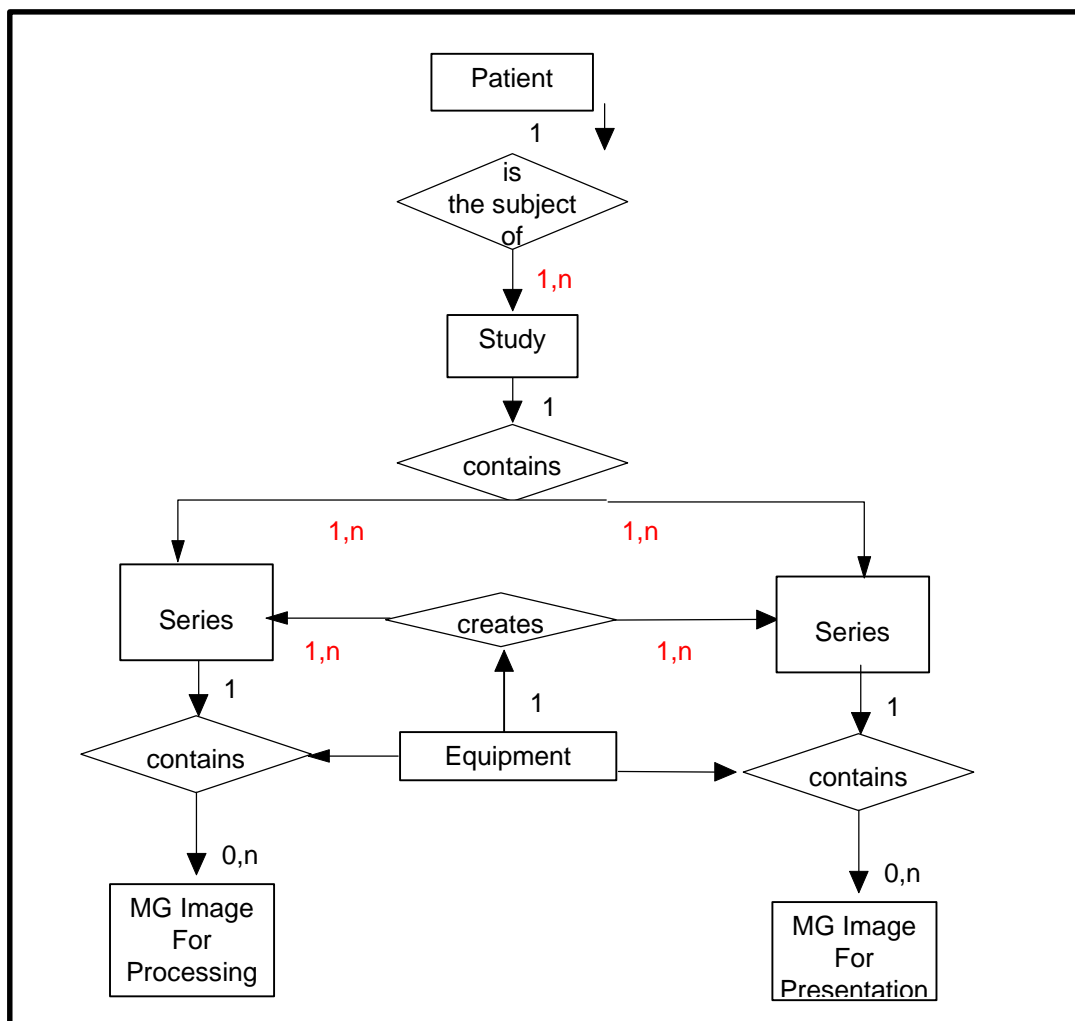

4.3.1 ENTITY DESCRIPTIONS

Please refer to DICOM Standard Part 3 (Information Object Definitions) and Supplement 32 for a description of each of the entities contained within the MG Information Object.

4.3.2 SENOGRAPHE 2000 D Acquisition Workstation Mapping of DICOM entities

TABLE 0-1
MAPPING OF DICOM ENTITIES TO SENOGRAPHE 2000 D ACQUISITION WORKSTATION ENTITIES

DICOM	SENOGRAPHE 2000 D Acquisition Workstation Entity
Patient	Patient
Study	Study
Series	Series
Image	Image
Frame	Not Applicable

4.4 IOD MODULE TABLE

Within an entity of the DICOM v3.0 MG IOD, attributes are grouped into related set of attributes. A set of related attributes is termed a module. A module facilitates the understanding of the semantics concerning the

attributes and how the attributes are related with each other. A module grouping does not infer any encoding of information into datasets.

Table 0-1 identifies the defined modules within the entities which comprise the DICOM v3.0 MG IOD.

Modules are identified by Module Name.

See DICOM v3.0 Part 3 and Supplement 32 for a complete definition of the entities, modules, and attributes.

**TABLE 0-1
MG IMAGE IOD MODULES**

Entity Name	Module Name	Reference
Patient	Patient	0
Study	General Study	0
Series	General Series	0
	DX Series	0
	Mammography Series	0
Equipment	General Equipment	0
Image	General Image	0
	Image Pixel	0
	X-Ray Acquisition Dose	0
	X-Ray Generation	0
	X-Ray Grid	0
	DX Anatomy Imaged	0
	DX Image	0
	Mammography Image	0
	DX Detector	0
	X-Ray Collimator	0
	DX Positioning	0
	Acquisition Context	0
	VOI LUT	0
Icon Image	0	
	SOP Common	0
Private Module	Application module	0

4.5 INFORMATION MODULE DEFINITIONS

Please refer to DICOM v3.0 Standard Part 3 (Information Object Definitions) and Supplement 32 for a description of each of the entities and modules contained within the Digital Mammography XRay Information Object.

The following modules are included to convey Enumerated Values, Defined Terms, and Optional Attributes supported. Type 1 & Type 2 Attributes are also included for completeness and to define what values they may take and where these values are obtained from. It should be noted that they are the same ones as defined in the DICOM v3.0 Standard Part 3 (Information Object Definitions).

4.5.1 Common Patient Entity Modules

4.5.1.1 Patient Module

This section specifies the Attributes of the Patient that describe and identify the Patient who is the subject of a diagnostic Study. This Module contains Attributes of the patient that are needed for diagnostic interpretation of the Image and are common for all studies performed on the patient.

**TABLE 0-1
PATIENT MODULE ATTRIBUTES**

Attribute Name	Tag	Type	Attribute Description
Patient's Name	(0010,0010)	2	The value is loaded from HIS/RIS or is entered by the user using the Medical Procedure Card.
Patient ID	(0010,0020)	2	The value is loaded from HIS/RIS or is entered by the user using the Medical Procedure Card.
Patient's Birth Date	(0010,0030)	2	The value is loaded from HIS/RIS or is entered by the user using the Medical Procedure Card.
Patient's Sex	(0010,0040)	2	The value is loaded from HIS/RIS or is entered by the user using the Medical Procedure Card.
Referenced Patient Sequence	(0008,1120)	3	This information is present only if retrieved from HISRIS.
>Referenced SOP Class UID	(0008,1150)	1C	
>Referenced SOP Instance UID	(0008,1155)	1C	

4.5.2 Common Study Entity Modules

The following Study IE Modules are common to all Composite Image IODs which reference the Study IE. These Module contain Attributes of the patient and study that are needed for diagnostic interpretation of the image.

4.5.2.1 General Study Module

This section specifies the Attributes which describe and identify the Study performed upon the Patient.

**TABLE 0-2
GENERAL STUDY MODULE ATTRIBUTES**

Attribute Name	Tag	Type	Attribute Description
Study Instance UID	(0020,000D)	1	The value is loaded from HIS/RIS or is generated by the system.
Study Date	(0008,0020)	2	The system set it to today's date when generating a new study.
Study Time	(0008,0030)	2	The system set it to current time when generating a new study.
Referring Physician's Name	(0008,0090)	2	The value is loaded from HIS/RIS or is entered by the user using the Medical Procedure Card.
Study ID	(0020,0010)	2	The value is loaded from HIS/RIS or is generated by the system.
Accession Number	(0008,0050)	2	The value is loaded from HIS/RIS or is entered by the user using the Medical Procedure Card.
Study Description	(0008,1030)	3	The value is loaded from HIS/RIS or is entered by the user using the Medical Procedure Card.
Referenced Study Sequence	(0008,1110)	3	This information is present only if retrieved from HISRIS.
>Referenced SOP Class UID	(0008,1150)	1C	
>Referenced SOP Instance UID	(0008,1155)	1C	

4.5.3 Common Series Entity Modules

The following Series IE Modules are common to all Composite Image IODs which reference the Series IE.

4.5.3.1 General Series Module

This section specifies the Attributes which identify and describe general information about the Series within a Study.

**TABLE 0-3
GENERAL SERIES MODULE ATTRIBUTES**

Attribute Name	Tag	Type	Attribute Description
Modality	(0008,0060)	1	Defined Terms: MG = Digital Mammography X-Ray
Series Instance UID	(0020,000E)	1	UID is generated by the system.
Series Number	(0020,0011)	2	Number generated by the system
Series Date	(0008,0021)	3	The system sets it to today's date when generating a new serie.
Series Time	(0008,0031)	3	The system sets it to current time when generating a new serie.
Performing Physicians' Name	(0008,1050)	3	The value is loaded from HIS/RIS or is entered by the user using the Medical Procedure Card.
Series Description	(0008,103E)	3	The value is loaded from HIS/RIS or is entered by the user using the Medical Procedure Card.
Operators' Name	(0008,1070)	3	The value is loaded from HIS/RIS or is entered by the user using the Medical Procedure Card.
Presentation Intent Type	(0008,0068)	1	Enumerated values: FOR PROCESSING in MG For Processing images. FOR PRESENTATION in MG For Presentation images.
Body Part Examined	(0018,0015)	3	Set to BREAST
Request Attributes Sequence	(0040,0275)	3	This information is present only if retrieved from HISRIS.
>Requested Procedure ID	(0040,1001)	1C	This information is present only if retrieved from HISRIS.
>Scheduled Procedure Step ID	(0040,0009)	1C	This information is present only if retrieved from HISRIS.
>Scheduled Procedure Step Description	(0040,0007)	3	This information is present only if retrieved from HISRIS.
>Scheduled Action Item Code Sequence	(0040,0008)	3	This information is present only if retrieved from HISRIS.

4.5.3.2 DX Series Module

This Module contains IOD Attributes that describe a Digital X-ray series performed on the patient.

**TABLE 0-4
DX SERIES MODULE ATTRIBUTES**

Attribute Name	Tag	Type	Attribute Description
Modality	(0008,0060)	1	Sent in General Series Module
Referenced Study Component Sequence	(0008,1111)	3	Sent in General Series Module
Presentation Intent Type	(0008,0068)	1	Sent in General Series Module

4.5.4 Common Equipment Entity Modules

The following Equipment IE Module is common to all Composite Image IODs which reference the Equipment IE.

4.5.4.1 General Equipment Module

This section specifies the Attributes which identify and describe the piece of equipment which produced a Series of Images.

**TABLE 0-5
GENERAL EQUIPMENT MODULE ATTRIBUTES**

Attribute Name	Tag	Type	Attribute Description
Manufacturer	(0008,0070)	2	Value set to "GE MEDICAL SYSTEMS"
Institution Name	(0008,0080)	3	Value comes from configuration file
Institution Address	(0008,0081)	3	Value comes from configuration file
Station Name	(0008,1010)	3	Value comes from configuration file
Institutional Department Name	(0008,1040)	3	Value comes from configuration file
Manufacturer's Model Name	(0008,1090)	3	Value set to "ADS_xx.yy" or "Senograph 2000D ADS_xx.yy" where xx.yy is the release number of the software that generated the image.
Software Versions	(0018,1020)	3	Value set to "ADS Application Package VERSION ADS xx.yy" where xx.yy is the release number of the software that generated the image.

4.5.5 Common Image Entity Modules

The following Image IE Modules are common to all Composite Image IODs which reference the Image IE.

4.5.5.1 General Image Module

This section specifies the Attributes which identify and describe an image within a particular series.

**TABLE 0-6
GENERAL IMAGE MODULE ATTRIBUTES**

Attribute Name	Tag	Type	Attribute Description
Image Number	(0020,0013)	2	Number generated by the system
Patient Orientation	(0020,0020)	2C	See 0.
Image Date	(0008,0023)	2C	Set by the system when building the image. Equal to Acquisition Date in MG For Processing image.
Image Time	(0008,0033)	2C	Set by the system when building the image. Equal to Acquisition Time in MG For Processing image.
Image Type	(0008,0008)	3	Value 1 is set to: ORIGINAL identifies an Original Image Value 2 is set to: PRIMARY identifies a Primary Image Value 3 is left EMPTY.
Acquisition Date	(0008,0022)	3	
Acquisition Time	(0008,0032)	3	
Source Image Sequence	(0008,2112)	3	<u>Only sent in MG for Presentation Images.</u>
>Referenced SOP Class UID	(0008,1150)	1C	
>Referenced SOP Instance UID	(0008,1155)	1C	
Lossy Image Compression	(0028,2110)	1	Always set to 00
Quality Control Image	(0028,0300)	3	
Burned In Annotation	(0028,0301)	1	Always set to NO

4.5.5.1.1 General Image Attribute Descriptions

4.5.5.1.1.1 Patient Orientation

Patient Orientation is set according to the Clinical View, as describe in the following table:

Clinical View	Patient Orientation (Row orientation / Column Orientation)
RCC, RXCCM, RXCCL, RXCC	P/L
CV	A/R
LCC, LXCCM, LXCCL, LXCC	A/R
RAT, LSIO	P/L
RFB	P/R
LFB	A/L
LAT, RSIO	A/FR
RML, LLM	P/F
LLMO, RMLO	P/FR
RLMO, LMLO	A/FL
LML, RML	A/F

4.5.5.1.1.2 Source Image Sequence

Source Image Sequence references the SOP Instance UID of the raw image (MG for Processing image) from which this processed image (MG for Presentation image) was created.

4.5.5.2 Image Pixel Module

This section specifies the Attributes that describe the pixel data of the image.

**TABLE 0-7
IMAGE PIXEL MODULE ATTRIBUTES**

Attribute Name	Tag	Type	Attribute Description
Samples per Pixel	(0028,0002)	1	Always set to 1
Photometric Interpretation	(0028,0004)	1	Set to MONOCHROME1 in MG For Processing images. Set to MONOCHROME2 in MG For Presentation images.
Rows	(0028,0010)	1	= 2294
Columns	(0028,0011)	1	= 1914
Bits Allocated	(0028,0100)	1	Set to 16
Bits Stored	(0028,0101)	1	Set to 14 for MG for Processing. Set to 12 for MG for Presentation
High Bit	(0028,0102)	1	Set to 13 for MG for Processing. Set to 11 for MG for Presentation
Pixel Representation	(0028,0103)	1	Always set to 0000H (unsigned integer)
Pixel Data	(7FE0,0010)	1	

4.5.5.3 X-Ray Acquisition Dose Modules

This section specifies the Attributes that describe the acquisition parameters used when acquiring the image.

**TABLE 0-8
X-RAY ACQUISITION DOSE MODULE ATTRIBUTES**

Attribute Name	Tag	Type	Attribute Description
Exposure Time	(0018,1150)	3	Unit: ms.
KVP	(0018,0060)	3	
X-Ray Tube Current	(0018,1151)	3	Unit: mA
Exposure	(0018,1152)	3	Unit: mAs
Entrance Dose	(0040,0302)	3	Unit: dGy
Organ Dose	(0040, 0316)	3	Unit: dGy
Body Part Thickness	(0018,11A0)	3	Unit: mm
Distance Source to Detector	(0018,1110)	3	Sent in DX Positioning Module
Distance Source to Patient	(0018, 1111)	3	Sent in DX Positioning Module
Distance Source to Entrance	(0040, 0306)	3	Unit: mm
Radiological Thickness	Private	3	Unit: mm
Comments on Radiation Dose	(0040,0310)	3	
Relative Xray Exposure	(0018,1405)	3	Set to pre-exposure Detector Entrance Dose in microGy
Anode Target Material	(0018,1191)	3	Sent in X-Ray Generation Module
Filter Material	(0018,7050)	3	Sent in X-Ray Filtration Module

4.5.5.4 X-RAY Generation Module

This section specifies the Attributes that describe the X-Ray generation when acquiring the image.

**TABLE 0-9
X-RAY GENERATION MODULE ATTRIBUTES**

Attribute Name	Tag	Type	Attribute Description
Exposure Time	(0018,1150)	3	Sent in X-Ray Acquisition Dose Module
KVP	(0018,0060)	3	Sent in X-Ray Acquisition Dose Module
Exposure	(0018,1151)	3	Sent in X-Ray Acquisition Dose Module
Anode Target Material	(0018,1191)	3	Set to MOLYBDENUM or RHODIUM
Focal Spot	(0018,1190)	3	Set to 0.1 or 0.3
Exposure Status	(0018,7064)	3	Defined Terms: NORMAL ABORTED
Exposure Control Mode	(0018,7060)	3	Defined Terms: MANUAL AUTOMATIC
Exposure Control Mode Description	(0018,7062)	3	Sent only if Exposure Control Mode is AUTOMATIC.

4.5.5.5 X-Ray FiltrationModule

This section specifies the Attributes that describe the filter used during acquisition.

**TABLE 0-10
X-RAY FILTRATION MODULE ATTRIBUTES**

Attribute Name	Tag	Type	Attribute Description
Filter Type	(0018,1160)	3	Set to STRIP
Filter Material	(0018,7050)	3	Set to MOLYBDENUM or ALUMINIUM or RHODIUM

4.5.5.6 X-Ray Grid Module

This section specifies the Attributes that describe the grid used during acquisition.

**TABLE 0-11
X-RAY GRID MODULE ATTRIBUTES**

Attribute Name	Tag	Type	Attribute Description
Grid	(0018,1166)	3	Value 1: RECIPROCATING Value 2: FOCUSED

4.5.5.7 DX Anatomy Imaged Module

The table in this Section contains IOD Attributes that describe the anatomy contained in a MG IOD.

**TABLE 0-12
DX ANATOMY IMAGED MODULE ATTRIBUTES**

Attribute Name	Tag	Type	Attribute Description
Image Laterality	(0020,0062)	1	Enumerated Values: R = right L = left B = both U = unpaired
Anatomic Region Sequence	(0008,2218)	2	
>Code Value	(0008,0100)	1C	Used Code: T-D4000 for Breast
>Coding Scheme Designator	(0008,0102)	1C	Always set to "SNM3"
>Code Meaning	(0008,0104)	1C	Set to Breast

4.5.5.8 DX Image Module

The table in this Section contains IOD Attributes that describe a DX image by specializing Attributes of the General Image and Image Pixel Modules, and adding additional attributes.

**TABLE 0-13
DX IMAGE MODULE ATTRIBUTES**

Attribute Name	Tag	Type	Attribute Description
Samples Per Pixel	(0028,0002)	1	Sent in Image Pixel module
Photometric Interpretation	(0028,0004)	1	Sent in Image Pixel module
Rows	(0028,0010)	1	Sent in Image Pixel module
Columns	(0028,0011)	1	Sent in Image Pixel module
Bits Allocated	(0028,0101)	1	Sent in Image Pixel module
Bits Stored	(0028,0101)	1	Sent in Image Pixel module
High Bit	(0028,0102)	1	Sent in Image Pixel module
Pixel Representation	(0028,0103)	1	Sent in Image Pixel module
Image Type	(0008,0008)	1	Sent in General Image Module
Pixel Intensity Relationship	(0028,1040)	1	Set to LIN in MG For Processing images. Set to LOG in MG For Presentation images.
Pixel Intensity Relationship Sign	(0028,1041)	1	Set to +1 in MG For Processing images. Set to -1 in MG For Presentation images.
Rescale Intercept	(0028,1052)	1	Always set to 0.
Rescale Slope	(0028,1053)	1	Always set to 1.
Rescale Type	(0028,1054)	1	Always set to US.
Presentation LUT Shape	(2050,0020)	1	Set to "INVERSE" in MG For Processing images. Set to "IDENTITY" in MG For Presentation images.
Lossy Image Compression	(0028,2110)	1	Sent in General Image Module
Patient Orientation	(0020, 0020)	1	Sent in General Image Module
Burned In Annotation	(0028,0301)	1	Sent in General Image Module

**SENOGRAPHE 2000 D ACQUISITION WORKSTATION
CONFORMANCE STATEMENT**

GE HEALTHCARE

2246811-2-1EN REV 1

Acquisition Device Processing Description	(0018,1400)	3	Sent only in MG For Presentation Images. Set to "GEMS_FFDM_TC_1", GEMS_FFDM_PV or GEMS_FFDM_AC_1
Acquisition Device Processing Code	(0018,1401)	3	Sent only in MG For Presentation Images. Set to "Proc 0", "Proc 1" or PREMIUM_VIEW
VOI LUT Sequence	(0028,3010)	3	Sent in VOI LUT Module
Window Center	(0028,1050)	1C	Sent in VOI LUT Module
Window Width	(0028,1051)	1C	Sent in VOI LUT Module
Window Center and Width Explanation	(0028,1055)	3	Sent in VOI LUT Module

4.5.5.9 DX Detector Module

The table in this Section contains IOD Attributes that describe a DX detector.

**TABLE 0-14
DX DETECTOR MODULE ATTRIBUTES**

Attribute Name	Tag	Type	Attribute Description
Detector Type	(0018,7004)	2	Set to "SCINTILLATOR"
Detector Configuration	(0018,7005)	3	Set to "AREA"
Detector ID	(0018,700A)	3	The ID or serial number of the detector used to acquire this image.
Detector Physical Size	(0018,7020)	3	Value 1 set to row dimension in mm. Value 2 set to column dimension in mm.
Detector Active Shape	(0018,7024)	3	Set to "RECTANGLE"
Detector Active Dimensions	(0018,7026)	3	Value 1 set to row dimension in mm. Value 2 set to column dimension in mm.
Field of View Shape	(0018,1147)	3	Set to "RECTANGLE"
Field of View Dimensions	(0018,1149)	3	Value 1 set to row dimension in mm. Value 2 set to column dimension in mm.
Field of View origin	(0018,7030)	1C	Sent if Field of View Rotation or Field of View Horizontal Flip is sent.
Field of View Rotation	(0018, 7032)	1C	Set to value of clockwise rotation in degrees of Field of View related to the physical detector. Sent if Field of View Horizontal Flip is sent.
Field of View Horizontal Flip	(0018, 7034)	1C	Enumerated values: YES NO Sent if Field of View Rotation is sent.
Detector Binning	(0018,701A)	3	Set to 1/1
Imager Pixel Spacing	(0018,1164)	1	Implementation limitation: Value is equal to the physical distance measured at the theoretical average breast height (e.g. 20 mm above the breast support) between the centers of each projected image pixel.
Detector Pixel Spacing	(0018, 7022)	3	Row dimension and column dimension set to 0.1
Detector Temperature	(0018,7001)	3	Sent if available
Sensitivity	(0018,6000)	3	Detector Sensitivity in manufacturer specific units.

Detector Conditions Nominal Flag	(0018,7000)	3	Enumerated values: YES NO
----------------------------------	-------------	---	---------------------------------

4.5.5.10 X-Ray Collimator Module

X-Ray Collimator module is optional and it is sent only if collimation has been applied while acquiring the image.

The table in this Section contains IOD Attributes that describe the collimation applied while acquiring the MG image.

**TABLE 0-15
X-RAY COLLIMATOR MODULE ATTRIBUTES**

Attribute Name	Tag	Type	Attribute Description
Collimator Shape	(0018,1700)	1	Set to "RECTANGLE".
Collimator Left Vertical Edge	(0018,1702)	1C	Sent if Collimator shape is sent.
Collimator Right Vertical Edge	(0018,1704)	1C	Sent if Collimator shape is sent.
Collimator Upper Horizontal Edge	(0018,1706)	1C	Sent if Collimator shape is sent.
Collimator Lower Horizontal Edge	(0018,1708)	1C	Sent if Collimator shape is sent.

4.5.5.11 DX Positioning Module

The table in this Section contains IOD Attributes that describe the positioning used in acquiring the MG image.

**TABLE 0-16
DX POSITIONING MODULE ATTRIBUTES**

Attribute Name	Tag	Type	Attribute Description
Distance Source to Detector	(0018,1110)	3	
Distance Source to Patient	(0018,1111)	3	
Body Part Thickness	(0018,11A0)	3	Sent in Xray Acquisition Dose Module
Compression Force	(0018,11A2)	3	unit: Newton
Estimated Radiographic Magnification Factor	(0018,1114)	3	Set to 1, 1.6 or 1.8
View Position	(0018,5101)	3	Set to ACR BI-RADS Equivalent of View Code. See Table
View Code Sequence	(0054,0220)	1	One item is sent in this sequence.
> Code Value	(0008,0100)	1	See list of view codes in Table Table 0-1 Mammography View Codes
> Code Scheme descriptor	(0008,0102)	1	Always set to "SNM3"
> Code Meaning	(0008,0104)	1	See list of view code meaning in Table 0-1 Mammography View Codes
>View Modifier Code Sequence	(0054,0222)	2	Several items can be sent in this sequence
>> Code Value	(0008,0100)	3	See list of view modifier codes in Table 0-1 Mammography View Modifier Codes
>> Code Scheme descriptor	(0008,0102)	3	Always set to "SNM3"
>> Code Meaning	(0008,0104)	3	See list of view modifier code meaning in Table 0-1 Mammography View Modifier Codes

Positioner Primary Angle	(0018,1510)	3	Set to value of Arm Compression Angle in degrees
Detector Primary Angle	(0018,1530)	3	Set to Tube arm angle in degrees
Positioner Type	(0018, 1508)	1	Set to MAMMOGRAPHIC

4.5.5.12 Mammo Series Module

The table in this Section contains IOD Attributes that describe the mammo series.

**TABLE 0-17
MAMMO SERIES MODULE ATTRIBUTES**

Attribute Name	Tag	Type	Attribute Description
Modality	(0008,0060)	1	Sent in General Series Module

4.5.5.13 Mammo ImageModule

The table in this Section contains IOD Attributes that describe the mammo image.

**TABLE 0-18
MAMMO IMAGE MODULE ATTRIBUTES**

Attribute Name	Tag	Type	Attribute Description
Anatomic Region Sequence	(0008,2218)	1	Sent in DX Anatomy Imaged Module
Image Laterality	(0020,0062)	1	Sent in DX Anatomy Imaged Module
View Code Sequence	(0054,0220)	1	Sent in DX Positioning Module
>View Modifier Code Sequence	(0054,0222)	2	Sent in DX Positioning Module
Positioner Primary Angle	(0018,1510)	1	Sent in DX Positioning Module
Positioner Type	(0018,1508)	1	Sent in DX Positioning Module
Organ Exposed	(0040,0318)	3	Set to BREAST

4.5.5.14 Acquisition Context Module

The table in this Section contains IOD Attributes that describe the acquisition context while acquiring the MG image.

**TABLE 0-19
ACQUISITION CONTEXT MODULE ATTRIBUTES**

Attribute Name	Tag	Type	Attribute Description
Acquisition Context Sequence	(0040,0555)	2	Zero length value is sent

4.5.5.15 VOI LUT module

The table in this Section contains IOD Attributes that describe the VOI LUT.

**TABLE 0-20
VOI LUT MODULE ATTRIBUTES**

Attribute Name	Tag	Type	Attribute Description
VOI LUT Sequence	(0028,3010)	3	Not sent
>LUT Descriptor	(0028,3002)	1C	Not sent
>LUT Explanation	(0028,3003)	3	Not sent
>LUT Data	(0028,3006)	1C	Not sent
Window Center	(0028,1050)	1C	Sent only in MG For Presentation Images Up to four values are present. The fourth value is present only when the user changes (by adjusting slider) the WW.

**SENOGRAPHE 2000 D ACQUISITION WORKSTATION
CONFORMANCE STATEMENT**

GE HEALTHCARE

2246811-2-1EN REV 1

Window Width	(0028,1051)	1C	Sent only in MG For Presentation Images Up to four values are present. The fourth value is present only when the user changes (by adjusting slider) the WW.
Window Center & Width Explanation	(0028,1055)	3	Sent only in MG For Presentation Images Up to four values are present. (NORMAL,SOFTER,HARDER,USER)
VOI LUT Function	(0028,1056)	3	Sent only in MG For Presentation Images Value sent: SIGMOID

4.5.5.16 Icon Image module

The table in this Section contains IOD Attributes that describe the icon image.

**TABLE 0-21
ICON IMAGE MODULE ATTRIBUTES**

Attribute Name	Tag	Type	Attribute Description
Icon Image Sequence	(0088,0200)	3	
>Samples Per Pixel	(0028,0002)	1C	Always set to 1
>Photometric Interpretation	(0028,0004)	1C	Always set to "MONOCHROME2"
>Rows	(0028,0010)	1C	Always <= 64
>Columns	(0028,0011)	1C	Always <= 64
>BitsAllocated	(0028,0100)	1C	Always equal to 8
>BitsStored	(0028,0101)	1C	Always equal to 8
>HighBit	(0028,0102)	1C	Always equal to 7
>Pixel Representation	(0028,0103)	1C	Always equal to 0
>Pixel Data	(7FE0,0010)	1C	

4.5.5.17 SOP Common Module

This section defines the Attributes which are required for proper functioning and identification of the associated SOP Instances. They do not specify any semantics about the Real-World Object represented by the IOD.

**TABLE 0-22
SOP COMMON MODULE ATTRIBUTES**

Attribute Name	Tag	Type	Attribute Description
SOP Class UID	(0008,0016)	1	
SOP Instance UID	(0008,0018)	1	Describe mechanism used to generate unique SOP Instance UIDs, eg. derived from serial number, site configuration, timestamp, etc.
Specific Character Set	(0008,0005)	1C	Set to ISO_IR 100 = Latin Alphabet No. 1
SC Instance UID	(0045,yy50)	3	UID to be set in SOP Instance UID of SC object created by SC fallback.
SC series UID	(0045,yy51)	3	UID to be set in Serie Instance UID of SC object created by SC fallback.

**SENOGRAPHE 2000 D ACQUISITION WORKSTATION
CONFORMANCE STATEMENT**

GE HEALTHCARE

2246811-2-1EN REV 1

4.5.6 Application Module (Private Module)

Application Module is a private module.

The table in this Section contains Attributes that describe various information required by the SENOGRAPHE 2000 D Acquisition Workstation Medical Application.

**TABLE 0-23
APPLICATION MODULE ATTRIBUTES**

Attribute Name	Tag	Type	Attribute Description
Clinical View	(0045,yy1b)	3	Used to store Clinical View to be displayed on the image.
Estimated Anat mean	(0045,yy20)	3	Used to store the Estimated Anatomical Mean.
MAO Buffer	(0045,yy26)	3	Used to store annotations added by user, such as graphics or text.
Windowing parameters	(0045,yy29)	3	Used to store windowing parameters.
2DLocX	(0045,yy2a)	3	Used to store X coordinates of the cross-hair cursor
2DLocY	(0045,yy2b)	3	Used to store Y coordinates of the cross-hair cursor
Radiological Thickness	(0045,yy49)	3	Used to store radiological thickness in mms.
mu	(0045,yy58)	3	Sent only in MG For Presentation Images. Used to store processing Algorithm parameters
Threshold	(0045,yy59)	3	Sent only in MG For Presentation Images. Used to store processing Algorithm parameters
Breast ROI X	(0045,yy60)	3	Sent only in MG For Presentation Images. Used to store Breast ROI x coordinates. (top_left,top_right,bottom_right,bottom_left)
Breast ROI Y	(0045,yy61)	3	Sent only in MG For Presentation Images. Used to store Breast ROI y coordinates (top_left,top_right,bottom_right,bottom_left)
User Window Center	(0045,yy62)	3	Sent in MG "FOR PROCESSING" and "FOR PRESENTATION" images. This value is of interest only in "FOR PROCESSING" images only. In "FOR PRESENTATION" images user window center is stored in the standard multivalued field (0028,1050)
User Window Width	(0045,yy63)	3	Sent in MG "FOR PROCESSING" and "FOR PRESENTATION" images. This value is of interest only in "FOR PROCESSING" images only. In "FOR PRESENTATION" images user window center is stored in the standard multivalued field (0028,1050)
Segm Threshold	(0045,yy64)	3	Sent only in MG For Processing Images. Used to store processing Algorithm parameters

4.6 PRIVATE DATA DICTIONARY

The table in this section describes the Private Attributes contained in MG images.

**TABLE 0-1
PRIVATE CREATOR IDENTIFICATION (GEMS_SENO_02)**

Attribute Name	Tag	VR	VM
Clinical View	(0045,yy1b)	CS	1
Estimated Anat mean	(0045,yy20)	DS	1
MAO Buffer	(0045,yy26)	OB	1
Windowing parameters	(0045,yy29)	DS	2
2DLocX	(0045,yy2a)	IS	1
2DLocY	(0045,yy2b)	IS	1
Radiological Thickness	(0045,yy49)	DS	1
SC Instance UID	(0045,yy50)	UI	1
SC series UID	(0045,yy51)	UI	1
mu	(0045,yy58)	DS	1
Threshold	(0045,yy59)	IS	1
Breast ROI X	(0045,yy60)	IS	4
Breast ROI Y	(0045,yy61)	IS	4
User Window Center	(0045,yy62)	IS	1
User Window Width	(0045,yy63)	IS	1
Segm Threshold	(0045,yy64)	IS	1

4.7 MAMMOGRAPHY VIEW CODES

Please find in Table below the list of view codes defined for Mammo images

**Table 0-1
Mammography View Codes**

Code Value (0008,0100)	Code Meaning (0008,0104)	ACR BI-RADS Equivalent
R-10224	medio-lateral	ML
R-10226	medio-lateral oblique	MLO
R-10228	latero-medial	LM
R-10230	latero-medial oblique	LMO
R-10242	cranio-caudal	CC
R-10244	caudo-cranial (from below)	FB
R-102D0	superolateral to inferomedial oblique	SIO
R-102CF	exaggerated cranio-caudal	XCC
Y-X1770	cranio-caudal exaggerated laterally	XCCL
Y-X1771	cranio-caudal exaggerated medially	XCCM

Please find below the list of View Modifier Codes defined for Mammo images:

**Table 0-1
Mammography View Modifier Codes**

Code Value (0008,0100)	Code Meaning (0008,0104)	Applies only when view is:	ACR BI-RADS Equivalent
R-102D2	Cleavage	CC	CV
R-102D1	Axillary Tail	MLO	AT
R-102D3	Rolled Lateral	any	...RL
R-102D4	Rolled Medial	any	...RM
R-102D5	Implant Displaced	any	ID
R-102D6	Magnification	any	M...
R-102D7	Spot Compression	any	S
R-102C2	Tangential	any	TAN

Note: In Senographe 2000 D Acquisition Workstation implementation, we don't use View Modifier Code Sequence field to encode Magnification. Magnification is derived from the value stored in Estimated Radiographic Magnification field (0018,1114)

5. STUDY ROOT QUERY/RETRIEVE INFORMATION MODEL DEFINITION

5.1 INTRODUCTION

This section specifies the use of the DICOM Study Root Query/Retrieve Model used to organize data and against which a Query/Retrieve will be performed. The contents of this section are:

- 0 - Information Model Description
- 0 - Information Model Entity-Relationship Model
- 0 - Information Model Keys

5.2 STUDY ROOT INFORMATION MODEL DESCRIPTION

5.3 STUDY ROOT INFORMATION MODEL ENTITY-RELATIONSHIP MODEL

The Entity-Relationship diagram for the Study Root Information Model schema is shown in Illustration 100H0-1. In this figure, the following diagrammatic convention is established to represent the information organization:

- each entity is represented by a rectangular box
- each relationship is represented by a diamond shaped box.
- the fact that a relationship exists between two entities is depicted by lines connecting the corresponding entity boxes to the relationship boxes.

The relationships are fully defined with the maximum number of possible entities in the relationship shown. In other words, the relationship between Series and Image can have up to n Images per Series.

ILLUSTRATION 0-1
STUDY ROOT QUERY/RETRIEVE INFORMATION MODEL E/R DIAGRAM

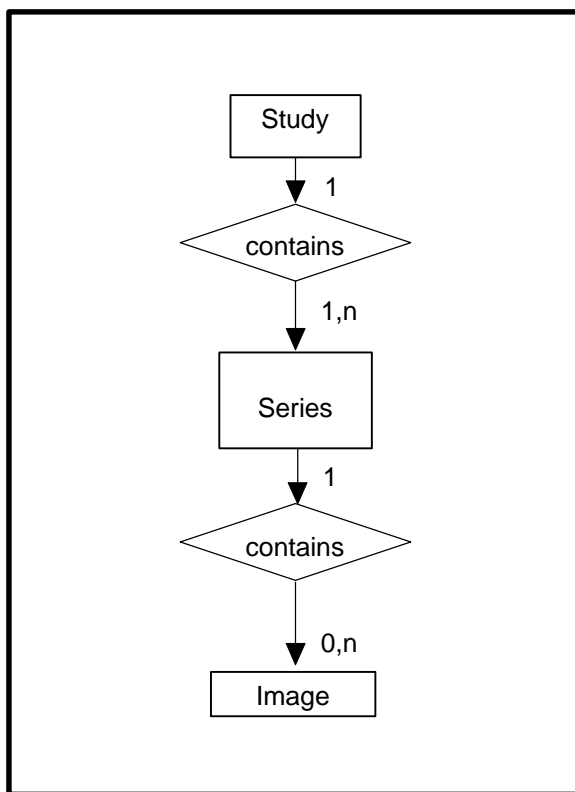

5.3.1 Entity Descriptions

Please refer to DICOM Standard PS 3.4 (Service Class Specifications) for a description of each of the levels contained within the Study Root Query/Retrieve Information Model.

5.3.2 SENOGRAPHE 2000 D Acquisition Workstation Mapping of DICOM entities

TABLE 0-1
MAPPING OF DICOM ENTITIES TO SENOGRAPHE 2000 D ACQUISITION WORKSTATION ENTITIES

DICOM	SENOGRAPHE 2000 D Acquisition Workstation Entity
Study	Study
Series	Series
Image	Image

5.4 INFORMATION MODEL KEYS

Please refer to DICOM Standard PS 3.4 (Service Class Specifications) for a description of each of the levels contained within the Study Root Query/Retrieve Information Model.

The following Level descriptions are included to specify what data elements are supported and what type of matching can be applied. It should be noted that they are the same ones as defined in the DICOM v3.0 Standard PS 3.4 (Service Class Specifications).

5.4.1 Supported Matching

Following are the types of matching that can be requested by the implementation:

- Single Value matching
- Universal Matching
- Wild Card Matching

– Range of date, Range of Time

5.4.2 Study Level

This section defines the keys at the Study Level of the Study Root Query/Retrieve Information Model that are supported by this implementation.

**TABLE 0-2
STUDY LEVEL ATTRIBUTES FOR THE STUDY ROOT
QUERY/RETRIEVE INFORMATION MODEL**

Attribute Name	Tag	Type	Attribute Description
Study Date	(0008,0020)	R	User Filtering is possible
Study Time	(0008,0030)	R	User Filtering is possible
Accession Number	(0008,0050)	R	
Patient's Name	(0010,0010)	R	User Filtering is possible
Patient ID	(0010,0020)	U	User Filtering is possible
Study ID	(0020,0010)	R	
Study Instance UID	(0020,000D)	U	
Study Description	(0008,0930)	U	User Filtering is possible

**TABLE 0-3
Q/R STUDY LEVEL AND LOCATION FOR RETRIEVE ATTRIBUTES**

Attribute Name	Tag	Type	Note
Query Retrieve Level	(0008,0052)	-	Value = STUDY

5.4.3 Series Level

This section defines the keys at the Series Level of the Study Root Query/Retrieve Information Model that are supported by this implementation.

**TABLE 0-4
SERIES LEVEL ATTRIBUTES FOR THE STUDY ROOT
QUERY/RETRIEVE INFORMATION MODEL**

Attribute Name	Tag	Type	Attribute Description
Modality	(0008,0060)	R	
Series Number	(0020,0011)	R	
Series Instance UID	(0020,000E)	U	
Series Description	(0008,103E)	U	User Filtering is possible

**TABLE 0-5
Q/R SERIES LEVEL AND LOCATION FOR RETRIEVE ATTRIBUTES**

Attribute Name	Tag	Type	Note
Query Retrieve Level	(0008,0052)	-	Value = SERIES

5.4.4 Image Level

This section defines the keys at the Image Level of the Study Root Query/Retrieve Information Model that are supported by this implementation.

**TABLE 0-6
IMAGE LEVEL ATTRIBUTES FOR THE STUDY ROOT
QUERY/RETRIEVE INFORMATION MODEL**

Attribute Name	Tag	Type	Attribute Description
Image Number	(0020,0013)	R	
SOP Instance UID	(0008,0018)	U	

**TABLE 0-7
Q/R IMAGE LEVEL AND LOCATION FOR RETRIEVE ATTRIBUTES**

Attribute Name	Tag	Type	Note
Query Retrieve Level	(0008,0052)	-	Value = IMAGE

5.5 PRIVATE DATA DICTIONARY

No private data dictionary is defined.

6. MODALITY WORKLIST INFORMATION MODEL DEFINITION

6.1 INTRODUCTION

This section specifies the use of the DICOM Modality Worklist Information Model used to organize data and against which a Modality Worklist Query will be performed. The contents of this section are:

- 0 - Information Model Description
- 0 - Information Model Entity-Relationship Model
- 0 - Information Model Module Table
- 0 - Information Model Keys

6.2 MODALITY WORKLIST INFORMATION MODEL DESCRIPTION

In order to serve as a Service Class Provider (SCP) of the Modality Worklist Service Class, a DICOM Application Entity (AE) possesses information about the attributes of a number of managed worklist items. These items are organized into Modality Worklist Information Modules. In this Service Class, the Information Model plays a role similar to an Information Object Definition of most other DICOM Service Classes.

6.3 MODALITY WORKLIST INFORMATION MODEL ENTITY-RELATIONSHIP MODEL

The Entity-Relationship diagram for the Modality Worklist Information Model schema is shown in Illustration 112H0-2. It represents the information that composes a Worklist Item. In this figure, the following diagrammatic convention is established to represent the information organization:

- each entity is represented by a rectangular box
- each relationship is represented by a diamond shaped box.
- the fact that a relationship exists between two entities is depicted by lines connecting the corresponding entity boxes to the relationship boxes.

ILLUSTRATION 0-2
 MODALITY WORKLIST INFORMATION MODEL E/R DIAGRAM

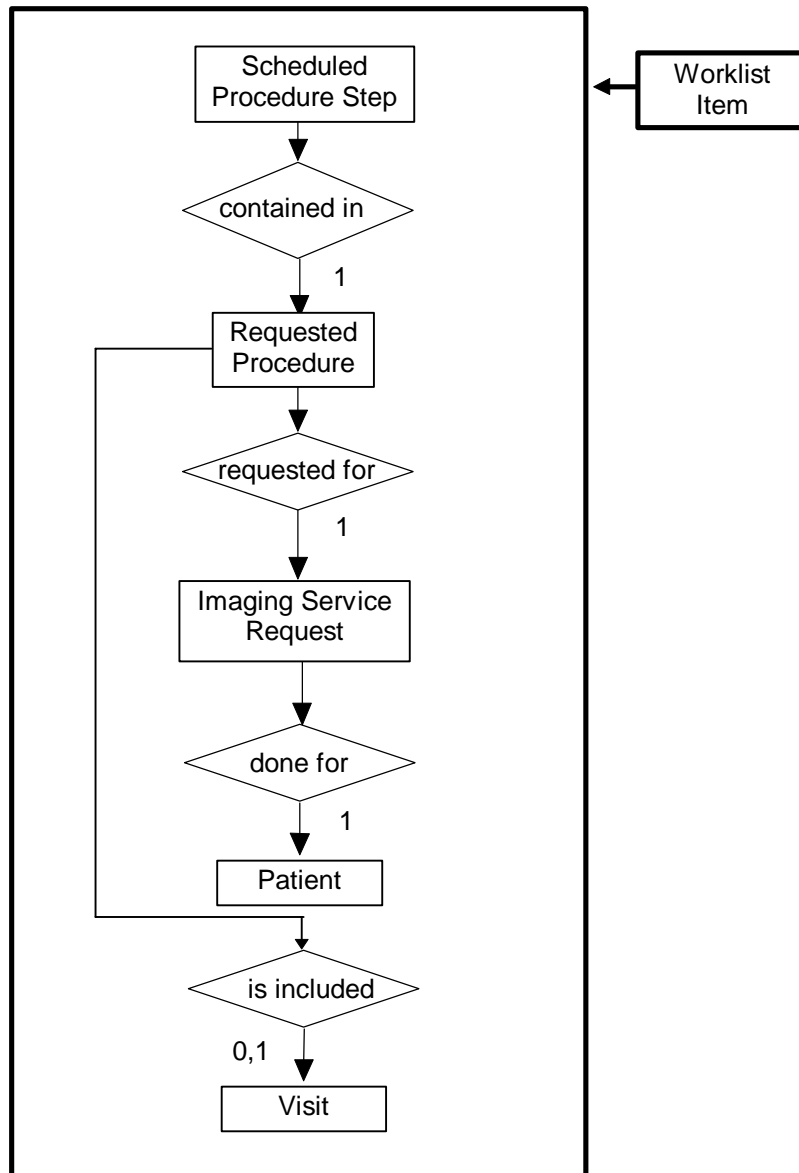

6.3.1 ENTITY DESCRIPTIONS

Please refer to DICOM Standard PS 3.3. (Information Object Definitions) and PS 3.4 (Service Class Specifications) for a description of each of the Entities contained within the Modality Worklist Information Model.

6.3.1.1 Scheduled Procedure Step

A Scheduled Procedure Step is an arbitrarily defined scheduled unit of service that is specified by the Procedure Plan for a Requested Procedure. It specifies one or more Action Items (events) involving equipment (i.e. imaging modality equipment), human resources, location and time (i.e. start time, stop time, duration).

6.3.1.2 Requested Procedure Entity Description

A Requested Procedure is an instance of a Procedure of a given Procedure Type. An instance of a Requested Procedure includes all of the items of information that are specified by an instance of a Procedure Plan that is selected for the Requested Procedure by the imaging service provider.

6.3.1.3 Imaging Service Request Entity Description

An Imaging Service Request is a set of one or more Requested Procedures selected from a list of Procedure Types. An Imaging Service Request is submitted by one authorized imaging service requester to one authorized imaging service provider in the context of one Service Episode.

6.3.1.4 Visit Entity Description

A Visit is the context in which the treatment or management of an arbitrary subset of a Patient’s medical conditions occurs. A Visit is limited to the description of a Patient’s activities at a single facility.

6.3.1.5 Patient Entity Description

A Patient is a person receiving, or registered to receive, healthcare services.

6.3.2 SENOGRAPHE 2000 D Acquisition Workstation Mapping of DICOM entities

**TABLE 0-1
MAPPING OF DICOM ENTITIES TO SENOGRAPHE 2000 D ACQUISITION WORKSTATION ENTITIES**

DICOM	SENOGRAPHE 2000 D Acquisition Workstation Entity
Scheduled Procedure Step	Serie
Requested Procedure	Study / Exam
Imaging Service Request	Study / Exam
Visit	Study / Exam
Patient	Patient

6.4 INFORMATION MODEL MODULE TABLE

Within an entity of the DICOM v3.0 Modality Worklist Information Model, attributes are grouped into related set of attributes. A set of related attributes is termed a module. A module facilitates the understanding of the semantics concerning the attributes and how the attributes are related with each other. A module grouping does not infer any encoding of information into datasets.

Table 0-1 identifies the defined modules within the entities which comprise the DICOM v3.0 Modality Worklist Information Model. Modules are identified by Module Name.

See DICOM v3.0 PS 3.3 and PS 3.4 for a complete definition of the entities, modules, and attributes.

**TABLE 0-1
MODALITY WORKLIST INFORMATION MODEL MODULES**

Entity Name	Module Name	Reference
Scheduled Procedure Step	SOP Common	0
	Scheduled Procedure Step	0
Requested Procedure	Requested Procedure	0
Imaging Service Request	Imaging Service Request	0
Visit	Visit Identification	0
	Visit Status	0
	Visit Relationship	0
	Visit Admission	0
Patient	Patient Relationship	0
	Patient Identification	0
	Patient Demographic	0
	Patient Medical	0

6.5 INFORMATION MODEL KEYS

Please refer to DICOM Standard PS 3.3. (Information Object Definitions) and PS 3.4 (Service Class Specifications) for a description of each of the Entities contained within the Modality Worklist Information Model.

The following Module descriptions are included to specify what data elements are supported and what type of matching can be applied. It should be noted that they are the same ones as defined in the DICOM v3.0 Standard PS 3.4 (Service Class Specifications) and include:

- Name
 - Tag group and element numbers
 - Expected Matching Key Type: R-required, O-optional
 - Expected Return Key Type:
 - 1 - non-zero value required
 - 1C - conditionally of type 1
 - 2 - required to be present, possibly with zero-length value
 - 2C - conditionally of type 2
 - 3 - optional
 - Mapped into The Image - whether this data is mapped into subsequently acquired images
 - Notes - clarification of this implementation's use/treatment of this attribute
- All data elements in the following Module descriptions are requested by default by the Worklist Server Data elements for which values can be sent for matching purposes are described as such. Data elements for which values are not sent are sent with zero length and universal matching will apply. This is the default case if no other description to the contrary is provided.

6.5.1 Supported Matching

Following are the types of matching that can be request by the implementation:

- Single Value matching
- Universal Matching
- Range of date, Range of Time

**SENOGRAPHE 2000 D ACQUISITION WORKSTATION
CONFORMANCE STATEMENT**

GE HEALTHCARE

2246811-2-1EN REV 1

6.5.2 Scheduled Procedure Step Entity

6.5.2.1 SOP Common Module

**TABLE 0-1
SOP COMMON MODULE ATTRIBUTES**

Attribute Name	Tag	Expected Matching Key Type	Expected Returned Key Type	Mapped into the Image	Displayed to User	Updatable by User	Note
Specific Character Set	(0008,0005)	O	1C	No	No	No	Matching is supported, the matching value is "ISO_IR100" and it is not dynamically configurable.

6.5.2.2 Scheduled Procedure Step Module

**TABLE 0-2
SCHEDULED PROCEDURE STEP MODULE ATTRIBUTES**

Attribute Name	Tag	Expected Matching Key Type	Expected Returned Key Type	Mapped into the Image	Displayed to User	Updatable by User	Note
Scheduled Procedure Step Sequence	(0040,0100)	R	1	No	N/A	N/A	
>Scheduled Station AE Title	(0040,0001)	R	1	No	No	No	Matching is supported as follow: either no AE title is supplied (universal matching), or the Query AE title (See Note) is supplied for matching; this is user selectable.
>Scheduled Procedure Step Start Date	(0040,0002)	R	1	No	Yes	No	Matching is supported as one of the following; this is user selectable: <ul style="list-style-type: none"> • today only, • tomorrow only, • from date1 to date2, date1 and date2 being defined by user Returned values must be exactly 8 numeric characters, in YYYYMMDD or YYYY.MM.DD format

**SENOGRAPHE 2000 D ACQUISITION WORKSTATION
CONFORMANCE STATEMENT**

GE HEALTHCARE

2246811-2-1EN REV 1

>Modality	(0008,0060)	R	1	No	No	No	Matching is supported as follows: either no Modality is supplied (universal matching), or the system's Modality is supplied (i.e. MG) for matching: this is user selectable.
>Scheduled Performing Physician's Name	(0040,0006)	R	2	Yes	Yes	Yes	
>Scheduled Procedure Step Description	(0040,0005)	O	1C	Yes	Yes	Yes	
>Scheduled Action Item Code Sequence	(0040,0008)	O	1C	No	No	No	
>>Code Value	(0008,0100)	O	1C	No	No	No	
>>Coding Scheme Designator	(0008,0102)	O	1C	No	No	No	
>>Code Meaning	(0008,0104)	O	3	No	No	No	
>Scheduled Procedure Step ID	(0040,0009)	O	1	No	No	No	

Note: The Query AE Title to use in Scheduled Station AE Title is defined in the Query section of the Worklist Configuration file: ~sdc/senovision/config/WorklistCfg.cfg

6.5.3 Requested Procedure Entity

6.5.3.1 Requested Procedure Module

**TABLE 0-3
REQUESTED PROCEDURE MODULE ATTRIBUTES**

Attribute Name	Tag	Expected Matching Key Type	Expected Returned Key Type	Mapped into the Image	Displayed to User	Updatable by User	Note
Requested Procedure ID	(0040,1001)	O	1	Yes	Yes	no	
Requested Procedure Description	(0032,1060)	O	1C	Yes	Yes	Yes	
Requested Procedure Code Sequence	(0032,1064)	O	1C	Yes	No	No	
>Code Value	(0008,0100)	O	1C	Yes	No	No	
>Coding Scheme Designator	(0008,0102)	O	1C	Yes	No	No	
>Code Meaning	(0008,0104)	O	3	Yes	No	No	
Study Instance UID	(0020,000D)	O	1	Yes	No	No	
Referenced Study Sequence	(0008,1110)	O	2	Yes	No	No	

>Referenced SOP Class UID	(0008,1150)	O	1C	Yes	No	No	
>Referenced SOP Instance UID	(0008,1155)	O	1C	Yes	No	No	

6.5.4 Imaging Service Request Entity

6.5.4.1 Imaging Service Request Module

**TABLE 0-4
IMAGING SERVICE REQUEST MODULE ATTRIBUTES**

Attribute Name	Tag	Expected Matching Key Type	Expected Returned Key Type	Mapped into the Image	Displayed to User	Updatable by User	Note
Accession Number	(0008,0050)	O	2	Yes	Yes	Yes if not provided by HIS	
Referring Physician's Name	(0008,0090)	O	2	Yes	Yes	Yes	

6.5.5 Visit Entity

6.5.5.1 Visit Identification

None of the data element from Visit Identification Module are requested

6.5.5.2 Visit Status

None of the data element from Visit Status Module are requested

6.5.5.3 Visit Relationship

**TABLE 0-5
VISIT RELATIONSHIP MODULE ATTRIBUTES**

Attribute Name	Tag	Expected Matching Key Type	Expected Returned Key Type	Mapped into the Image	Displayed to User	Updatable by User	Note
Referenced Patient Sequence	(0008,1120)	O	2	Yes	No	No	
>Referenced SOP Class UID	(0008,1150)	O	2	Yes	No	No	
>Referenced SOP Instance UID	(0008,1155)	O	2	Yes	No	No	

6.5.5.4 Visit Admission

None of the data elements from Visit Admission Module are requested.

6.5.6 Patient Entity

6.5.6.1 Patient Relationship

None of the data elements from Patient Relationship Module are requested.

6.5.6.2 Patient Identification

**TABLE 0-6
PATIENT IDENTIFICATION MODULE ATTRIBUTES**

Attribute Name	Tag	Expected Matching Key Type	Expected Returned Key Type	Mappe d into the Image	Displayed to User	Updatable by User	Note
Patient's Name	(0010,0010)	R	1	Yes	Yes	Yes if not provided by HIS	Matching is supported as follow: either no patient name is supplied (universal matching), or the patient name entered by the user in the Query Definition screen is supplied for matching
Patient ID	(0010,0020)	R	1	Yes	Yes	Yes if not provided by HIS	Matching is supported as follow: either no patient ID is supplied (universal matching), or the patient ID entered by the user in the Query Definition screen is supplied for matching

6.5.6.3 Patient Demographic

**TABLE 0-7
PATIENT DEMOGRAPHIC MODULE ATTRIBUTES**

Attribute Name	Tag	Expected Matching Key Type	Expected Returned Key Type	Mappe d into the Image	Displayed to User	Updatable by User	Note
Patients Birth Date	(0010,0030)	O	2	Yes	Yes	Yes	
Patient's Sex	(0010,0040)	O	2	Yes	Yes	Yes	

6.5.6.4 Patient Medical

None of the data elements from Patient Medical Module are requested

6.6 PRIVATE DATA DICTIONARY

The SENOGAPHE 2000 D Acquisition Workstation implementation does not define any Private Attributes within the Modality Worklist Information Model.

7. NETWORK PRINT SCU CONFORMANCE STATEMENT

7.1 INTRODUCTION

This section of the DICOM Conformance Statement specifies the compliance to DICOM conformance requirements for the relevant Grayscale **Network Printing** features on this GEMS product. Note that the format of this section strictly follows the format defined in DICOM Standard PS 3.2 (Conformance). Please refer to that part of the standard while reading this section.

The Senographe 2000 D Acquisition Workstation has the ability to compose films through the use of an applications known as PRINT MANAGER. The Senographe 2000 D Acquisition Workstation uses DICOM Print Management Service Class to send images to hard copy printers. The films can then be used for possible further analysis.

7.2 IMPLEMENTATION MODEL

7.2.1 Application Data Flow Diagram

The Basic and Specific Application models for this device are shown in the following Illustration:
DICOM Print SCU Application Entity Model

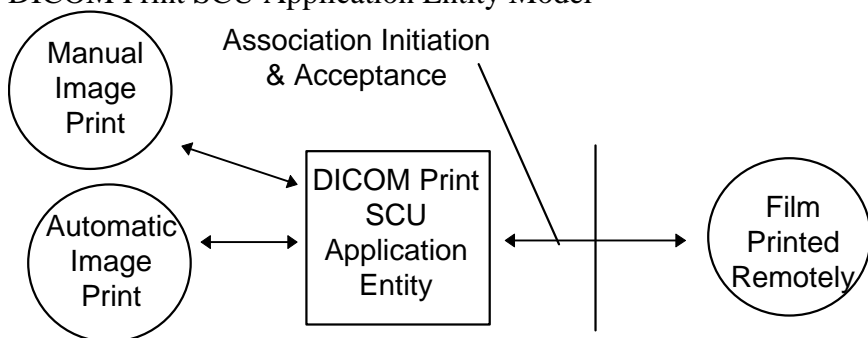

The DICOM Print SCU Application Entity (AE) is an application which handles DICOM protocol communication with Remote DICOM Printers. The DICOM Print SCU AE is activated when the user requests for a print or when automatic print is triggered at close exam time.

The DICOM Print SCU AE is invoked by the following Real World Activity:

- Manual Image Print.
For this operation, the operator selects an image in the VIEWER, then prints the image clicking on the PRINT button.
- Automatic Image Print
For this operation, user set Auto-Print ON. Then when he acquires images, images are automatically printed at Close Exam time.

In manual or automatic print, the PRINT MANAGER receives the “Simple print” request, composes a film then send the film to the selected Remote DICOM Printer.

7.2.2 Functional Definition of AE's

The DICOM Print SCU AE supports the following functions:

- Access to pixel data in the local database.
- Initiate a DICOM association to send DICOM SOP Classes (corresponding to the DICOM Print Management service class) to a remote DICOM Printer.

7.2.3 Sequencing of Real-World Activities

7.2.3.1 Manual Image Print

1. The user selects the remote DICOM Printer from the Print Manager GUI.

2. The user selects an image in the VIEWER, then prints the image using the “Simple print” function.
 3. The PRINT MANAGER receives the “Simple print” request, composes a film then activates the DICOM Print SCU AE that initiate the following actions.
 4. Initiates a DICOM association and selects a Presentation Context
 5. N-GETs printer status from the Printer SOP Instance
 - If Printer Status is FAILURE
 - Signal print failure to the user
 - Association is aborted
 - Else If Printer Status is WARNING and Printer Status Info is not equal to SUPPLY LOW or SUPPLY EMPTY
 - Signal print warning to the user
 - Association is released
 6. N-CREATES a Basic Film Session SOP Instance
 7. N-CREATES a Basic Film Box SOP Instance for the current film
 8. N-SETs the Basic Film Box SOP Instance with the Image Box SOP Instance for each image on the film
 9. N-ACTIONS on the Basic Film Box SOP Instance
 10. N-DELETES on the Basic Film Box SOP Instance
- If DICOM_PRINT_WAIT_SCP_EVENT environment variable is set
11. Wait for N-EVENT-REPORTs of the Printer SOP Instance indicating printer status
 12. If no N-EVENT-REPORT has been received after a configurable time out performs an NGET to obtain the printer status from the Printer SOP Instance
(The time out value is defined in the file ~sdc/app-defaults/dicom_print/dprint.cfg)
- end condition
13. Releases the DICOM association after printing is successful or failure has been signaled to the user

7.2.3.2 Automatic Image Print

Same as Manual Print except step 1 and 2 to be replaced by:

1. User sets Auto-Print ON and defines auto-print parameters.
2. User starts an exam, acquires images and clicks on CLOSE EXAM.

7.3 AE SPECIFICATIONS

7.3.1 DICOM Print SCU AE Specification

This Application Entity provides Standard Conformance to the following DICOM V3.0 SOP Classes as a SCU:

SOP Class Name	SOP Class UID
Basic Grayscale Print Management Meta SOP Class	1.2.840.10008.5.1.1.9

Note: Support of the Basic Grayscale Print Management Meta SOP Class as an SCU mandates support for the Basic Film Session, Basic Film Box, Basic Grayscale Image Box and Printer SOP Classes as a SCU.

7.3.1.1 Association Establishment Policies

7.3.1.1.1 General

The DICOM Application Context Name (ACN), which is always proposed, is:

Application Context Name	1.2.840.10008.3.1.1.1
---------------------------------	------------------------------

The Maximum Length PDU negotiation is included in all association establishment requests.
The maximum length PDU for an association initiated by the DICOM Print SCU is:

Maximum Length PDU	16384
---------------------------	--------------

The Print Management Service Class does not support extended negotiation.
The maximum number of Presentation Context Items that will be proposed is: 6
The user information Items sent by this product are:

- Maximum PDU Length
- Implementation UID
- Implementation Version Name

Note: The maximum PDU length can be modified at installation time. 0 as PDU length is not supported by this implementation.

7.3.1.1.2 Number of Associations

The DICOM Print SCU AE supports only one association at a time. Request are internally queued.

7.3.1.1.3 Asynchronous Nature

Asynchronous mode is not supported. All operations will be performed synchronously.

7.3.1.1.4 Implementation Identifying Information

The Implementation UID for this DICOM v3.0 Implementation is:

Senographe 2000 D Acquisition Workstation Implementation UID	1.2.840.113619.6.66
---	----------------------------

The Implementation Version Name for this DICOM v3.0 Implementation is:

Senographe 2000 D Acquisition Workstation Implementation Version Name	1_2_10
--	---------------

7.3.1.2 Association Initiation Policy

The DICOM Print SCU AE initiates one association with the selected REMOTE DICOM Printer. No other association can be opened by the DICOM Print SCU AE while the current association is active.

7.3.1.2.1 Real-World Activity “Manual Image Print”

7.3.1.2.1.1 Associated Real-World Activity

The operator does the following:

1. Selects an image in Viewer.
2. Clicks on Print Button
3. Print window is displayed. User checks or modifies selected printer and print parameters (film format, number of copies, pixel depth, etc...).
4. Clicks on Print to confirm.

This operation will cause the DICOM PRINT SCU AE to try to establish the association with the requested printer and sends the images for printing.

7.3.1.2.1.2 Proposed Presentation Context Table

Presentation Context Table - Proposed					
Abstract Syntax		Transfer Syntax		Role	Extended Negotiation
Name	UID	Name List	UID List		
Basic Grayscale Print Management Meta SOP Class	1.2.840.10008.5.1.1.9	Implicit VR Little Endian	1.2.840.10008.1.2	SCU	None

7.3.1.2.1.2.1 SOP Specific DICOM Conformance Statement for Print Management SOP Classes

For each of the supported Print Management SOP and Meta SOP Classes, the optional attributes and service elements supported, the valid range of values for mandatory and optional attributes, and the status code behavior are described in Annex.

7.3.1.2.2 Real-World Activity “Automatic Image Print”

7.3.1.2.2.1 Associated Real-World Activity

The operator does the following:

1. Set Auto-Print ON and define the auto-print parameters using MEDICAL APPLICATION PREFERENCES option of the Browser toolkit menu.
2. Starts an exam
3. Acquires images
4. Clicks on CLOSE EXAM

This operation will cause the DICOM PRINT SCU AE to try to establish the association with the requested printer and sends the acquired images for printing.

7.3.1.2.2.2 Proposed Presentation Context Table

Same as “Manual Image Print” real world activity.

7.3.1.2.2.2.1 SOP Specific DICOM Conformance Statement for Print Management SOP Classes

Same as “Manual Image Print” real world activity.

7.4 COMMUNICATION PROFILES

7.4.1 Supported Communication Stacks (PS 3.8, PS 3.9)

DICOM Upper Layer (PS 3.8) is supported using TCP/IP.

7.4.2 OSI Stack

OSI stack not supported

7.4.3 TCP/IP Stack

The TCP/IP stack is inherited from a UNIX Operating System.

7.4.3.1 API

Not applicable to this product.

7.4.3.2 Physical Media Support

DICOM is indifferent to the Physical medium over which TCP/IP executes (e.g. Ethernet V2.0, IEEE 802.3, ATM, FDDI)

Note: For more information about the Physical Media available on SENOGRAPHE 2000 D Acquisition Workstation, please refer to the Product Data Sheet.

7.4.4 Point-to-Point Stack

A 50-pin ACR-NEMA connection is not applicable to this product.

7.5 EXTENSIONS / SPECIALIZATIONS / PRIVATIZATIONS

7.5.1 Standard Extended /Specialized/Private SOP Classes

No Standard Extended, no Specialized, no Private SOP Classes are managed by this application.

7.5.2 Private Transfer Syntaxes

No Private Transfer Syntaxes are managed by this product.

7.6 CONFIGURATION

7.6.1 AE Title/Presentation Address Mapping

The local DICOM Print SCU AE Title is “PR_hostname” where hostname is the system hostname defined at installation time. The Print SCU AE Title value is defined in the file:

~sdc/app-defaults/dicom_print/dprint.cfg

The PRINT MANAGER application allows the user to add, delete, or update the following Remote DICOM Printers parameters:

- AE Title
- DICOM Port Number
- IP address

7.6.2 Configurable Parameters

For this AE (local), the following fields are configurable in the file
~sdc/app-defaults/dicom_print/dprint.cfg:

- Local AE Title
- Local IP Address
- Local IP Netmask

Note: The local Port Number may be not applicable because the product is never responding to an association request.

The following fields are configurable for every remote DICOM AE:

- Remote AE Title
- Remote IP Address
- Listening TCP/IP Port Number

Only one default router IP Address can be configured for all DICOM remote nodes (including printers, Storage SCP Workstations, ...)

The following fields are configurable:

- Association Establishment Timer (default set to 600s)
- N-SET timer (default set to 300s)
- N-ACTION timer (default set to 300s)
- N-GET timer (default set to 300s)
- N-DELETE timer (default set to 300s)
- Inactivity Timers (default set to 3000s)
- N-EVENT timer (default set to 30s)

- Maximum Length PDU

Note: All configurations must be performed by a GE Field Engineer.

Note: Only one association can be performed at a time by this implementation.

7.7 SUPPORT OF EXTENDED CHARACTER SETS

The SENOGRAPHE 2000 D Acquisition Workstation will support only the ISO_IR 100 (ISO 8859-1:1987 Latin alphabet N 1. supplementary set) as extended character sets. Any incoming SOP instance that is encoded using another extended character set will not be installed in the local database.

8. PRINT MANAGEMENT SOP CLASS DEFINITION

8.1 INTRODUCTION

This section of the DICOM Conformance Statement specifies the supported Print Management SOP and Meta SOP Classes, the optional attributes and service elements supported, the valid range of values for mandatory and optional attributes, and the status code behavior.

This section contains:

- 0- 8.2.1 Basic Film Session SOP Class
- 0 - 8.2.2 Basic Film Box SOP Class
- 0 - Image Box SOP Classes
- 0 - 8.2.4 Printer SOP Class
- 0 - If Printer Status is FAILURE

Signal print failure to the user

Else If Printer Status is WARNING and Printer Status Info is not equal to SUPPLY LOW or SUPPLY EMPTY

Signal print warning to the user

Else

Signal print success to the user

8.2.5 Print Job SOP Class

- 0- 8.2.6 Basic Annotation Box SOP Class
- 0 - 8.2.7 Image Overlay Box SOP Class

8.2 PRINT MANAGEMENT SOP CLASS DEFINITIONS

8.2.1 Basic Film Session SOP Class

The DICOM Print SCU AE supports the N-CREATE DIMSE Service Element for the Basic Film Session SOP Class.

- The N-CREATE DIMSE Service element sent by the DICOM Print SCU AE requests the Remote DICOM Print SCP to create an instance of Basic Film Session.

8.2.1.1 IOD Description

8.2.1.1.1 IOD modules

Module	Reference	Module Description
SOP Common		Contains SOP Common information
Basic Film Session Presentation Module	0	Contains Film Session presentations information
Basic Film Session Relationship	0	References to related SOPs

8.2.1.1.2 Basic Film Session Presentation Module

Attribute name	Tag	Attribute Description
Number of Copies	(2000,0010)	1 to 10.
Print Priority	(2000,0020)	HIGH or MED or LOW depending of configuration of associated Remote DICOM printer.
Film Session Label	(2000,0050)	Human readable label that identifies the film session. depending of configuration of associated Remote DICOM printer. Empty by default or set to free text.
Medium Type	(2000,0030)	PAPER or CLEAR FILM or BLUE FILM depending of configuration of associated Remote DICOM printer
Film Destination	(2000,0040)	MAGAZINE or PROCESSOR depending of configuration of associated Remote DICOM printer

8.2.1.1.3 Basic Film Session Relationship Module

Attribute Name	Tag	Attribute Description
Referenced Film Box Sequence	(2000,0500)	Empty
>Referenced SOP Class UID	(0008,1150)	Empty
>Referenced SOP Instance UID	(0008,1155)	Empty

8.2.1.2 DIMSE Service Group

DIMSE Service Element	Usage SCU
N-CREATE	M
N-SET	Not used
N-DELETE	Not used
N-ACTION	Not used

8.2.1.2.1 N-CREATE

8.2.1.2.1.1 Attributes

Attribute Name	Tag	Usage SCU
Number of Copies	(2000,0010)	Used
Print Priority	(2000,0020)	Used
Medium Type	(2000,0030)	Used
Film Session Label	(2000,0050)	Used, not sent if empty

Memory Allocation	(2000,0060)	Not used
Film Destination	(2000,0040)	Used

8.2.1.2.1.2 Status

Service Status	Status Codes	Further Meaning	Application Behavior When receiving Status Codes
Warning	B600	Memory allocation not supported	Association is aborted
Success	0000	Film session successfully created	Next step describe in the sequencing of Real-World Activities paragraph is performed

8.2.1.2.1.3 Behavior

No specific behavior.

8.2.1.2.2N-SET

This service is not used.

8.2.1.2.3N-DELETE

This service is not used.

8.2.1.2.4N-ACTION

This service is not used.

8.2.2 Basic Film Box SOP Class

The DICOM Print SCU AE supports the following DIMSE Service Element for the Basic Film Box SOP Class.

- The N-CREATE DIMSE Service element sent by the DICOM Print SCU AE requests the Remote DICOM Print SCP to create an instance of Basic Film Box
- The N-ACTION DIMSE Service element sent by the DICOM Print SCU AE requests the Remote DICOM Print SCP to print the Basic Film Box onto the hard copy printer.
- The N-DELETE DIMSE Service element sent by the DICOM Print SCU AE requests the Remote DICOM Print SCP to release the Basic Film Box instance.

8.2.2.1 IOD Description

8.2.2.1.1 IOD modules

Module	Reference	Module Description
SOP Common		Contains SOP Common information
Basic Film Box Presentation Module	0	Contains Film Box presentation information
Basic Film Box Relationship	0	References to related SOPs

8.2.2.1.2 Basic Film Box Presentation Module

Attribute Name	Tag	Attribute Description
Image Display Format	(2010,0010)	STANDARD\C,R [C 1 to 5] and [R 1 to 4] SLIDE SUPERSLIDE
Annotation Display Format ID	(2010,0030)	Not sent.
Film Orientation	(2010,0040)	PORTRAIT LANDSCAPE
Film Size ID	(2010,0050)	8INX10IN 10INX12IN 10INX14IN 11INX14IN 14INX14IN 14INX17IN 24CMX24CM 24CMX30CM
Border density	(2010,0100)	BLACK or WHITE depending of configuration of associated Remote DICOM printer.
Empty Image Density	(2010,0110)	BLACK or WHITE depending of configuration of associated Remote DICOM printer.
Magnification Type	(2010,0060)	One of the following defined term is sent: REPLICATE BILINEAR CUBIC NONE
Smoothing Type	(2010,0080)	Only valid for Magnification type = CUBIC
Min Density	(2010,0120)	-1 by default or set to positive integer
Max Density	(2010,0130)	-1 by default or set to positive integer
Trim	(2010,0140)	Empty by Default or set to YES or NO according to value set by user when declaring the printer
Configuration Information	(2010,0150)	Empty by default or set to a value defined when printer is declared.

8.2.2.1.3 Basic Film Box Relationship Module

Attribute Name	Tag	Attribute Description
Referenced Film Session Sequence	(2010,0500)	Empty
>Referenced SOP Class UID	(0008,1150)	Empty
>Referenced SOP Instance UID	(0008,1155)	Empty
Referenced Image Box Sequence	(2010,0510)	Empty
>Referenced SOP Class UID	(0008,1150)	Empty
>Referenced SOP Instance UID	(0008,1155)	Empty
Referenced Basic Annotation Box Sequence	(2010,0520)	Empty
>Referenced SOP Class UID	(0008,1150)	Empty
>Referenced SOP Instance UID	(0008,1155)	Empty

8.2.2.2 DIMSE Service Group

DIMSE Service Element	Usage SCU
N-CREATE	M
N-ACTION	M
N-DELETE	Used

8.2.2.2.1N-CREATE

8.2.2.2.1.1 Attributes

Attribute Name	Tag	Usage SCU
Image Display Format	(2010,0010)	M
Referenced Film Session Sequence	(2010,0500)	M
>Referenced SOP Class UID	(0008,1150)	M
>Referenced SOP Instance UID	(0008,1155)	M
Referenced Image Box Sequence	(2010,0510)	Not used
>Referenced SOP Class UID	(0008,1150)	Not used
>Referenced SOP Instance UID	(0008,1155)	Not used
Referenced Basic Annotation Box Sequence	(2010,0520)	Not used
>Referenced SOP Class UID	(0008,1150)	Not used
>Referenced SOP Instance UID	(0008,1155)	Not used
Film Orientation	(2010,0040)	Used
Film Size ID	(2010,0050)	Used
Magnification Type	(2010,0060)	Used
Max Density	(2010,0130)	Used, not sent if = -1
Configuration Information	(2010,0150)	Used, not sent if empty
Annotation Display Format ID	(2010,0030)	Not used
Smoothing Type	(2010,0080)	Used, not sent if empty or magnification is not equal to CUBIC
Border Density	(2010,0100)	Used
Empty Image Density	(2010,0110)	Used
Min Density	(2010,0120)	Used, not sent if = -1
Trim	(2010,0140)	Used, not sent if empty

8.2.2.2.1.2 Status

There are no specific status codes.

8.2.2.2.1.3 Behavior

There is no specific behavior.

8.2.2.2.2N-DELETE

8.2.2.2.2.1 Behavior

The SCU uses the N-DELETE to request the SCP to delete the Basic Film Box SOP Instance hierarchy.

8.2.2.2.3N-ACTION

N-ACTION is used to print the current film of the film session.

8.2.2.2.3.1 Attributes

Action Type Name	Action Type ID	Attribute	Tag	Usage SCU
Print	1	Referenced Print Job Sequence	(2100,0500)	Not used
		>Referenced SOP Class UID	(0008,1150)	Not used
		>Referenced SOP Instance UID	(0008,1155)	Not used

8.2.2.2.3.2 Status

Service Status	Status Codes	Further Meaning	Application Behavior When receiving Status Codes
Success	0000	Film accepted for printing.	Next step describe in the sequencing of Real-World Activities paragraph is performed
Warning	B603	Film Box SOP Instance hierarchy does not contain Image Box SOP Instances (empty page)	This case should not happen. This warning is considered as an error. Association is aborted.
Failure	C602	Unable to create Print Job SOP Instance; print queue is full	Appropriate message is returned to the user. Association is aborted.
	C604	Image position collision: multiple images assigned to single image position	Appropriate message is returned to the user. Association is aborted.
	C603	Image size is larger than image box size (by using the specified magnification value)	Appropriate message is returned to the user. Association is aborted.

8.2.2.2.3.3 Behavior

SCU uses the N-ACTION to request the SCP to print one or more copies of a single film of the film session.

8.2.3 Image Box SOP Classes

8.2.3.1 Basic Grayscale Image Box SOP Class

The DICOM Print SCU AE supports the following DIMSE Service Element for the Basic Grayscale Image Box SOP Class.

- The N-SET DIMSE Service element sent by the DICOM Print SCU AE requests the Remote DICOM Print SCP to set the attributes of the Basic Grayscale Image Box Instance.

8.2.3.1.1 IOD description

8.2.3.1.1.1 IOD modules

Module	Reference	Module Description
SOP Common		Contains SOP Common information
Image Box Presentation Module	0	Contains Image Box presentation information
Image Box Relationship Module	0	References to related SOPs

8.2.3.1.1.2 Image Box Pixel Presentation Module

Attribute Name	Tag	Attribute Description
Image Position	(2020,0010)	1
Polarity	(2020,0020)	NORMAL = pixels shall be printed as specified by the Photometric Interpretation (0028,0004) REVERSE = pixels shall be printed with the opposite polarity as specified by the Photometric Interpretation (0028,0004)
Magnification Type	(2010,0060)	Same value as defined in the Film Box.
Smoothing Type	(2010,0080)	Same value as defined in the Film Box
Configuration Information	(2010,0150)	Same value as defined in the Film Box.
Requested Image Size	(2020,0030)	Not Sent
Preformatted Grayscale Image Sequence	(2020,0110)	This sequence is always included if the Image Box is a Basic Grayscale Image Box
>Samples Per Pixel	(0028,0002)	1
>Photometric Interpretation	(0028,0004)	MONOCHROME1 or MONOCHROME2 depending of configuration of associated Remote DICOM printer.
>Rows	(0028,0010)	Original image height
>Columns	(0028,0011)	Original image width
>Pixel Aspect Ratio	(0028,0034)	1\1
>Bits Allocated	(0028,0100)	Depends on the original image pixel depth (8 or 16).
>Bits Stored	(0028,0101)	Original image pixel depth (8, 10 or 12 bits).
>High Bit	(0028,0102)	Depends on the original image pixel depth (7, 9 or 11).
>Pixel Representation	(0028,0103)	0 (Unsigned Integer)
>Pixel Data	(7FE0,0010)	

8.2.3.1.1.3 Image Box Relationship Module

Attribute Name	Tag	Attribute Description
Referenced Image Sequence	(0008,1140)	Not used
>Referenced SOP Class UID	(0008,1150)	Not used
>Referenced SOP Instance UID	(0008,1155)	Not used
>Referenced Frame Number	(0008,1160)	Not used
Referenced Image Overlay Box Sequence	(2020,0130)	Not used
>Referenced SOP Class UID	(0008,1150)	Not used
>Referenced SOP Instance UID	(0008,1155)	Not used

>Referenced Frame Number	(0008,1160)	Not used
Referenced VOI LUT Sequence	(2020,0140)	Not used
>Referenced SOP Class UID	(0008,1150)	Not used
>Referenced SOP Instance UID	(0008,1155)	Not used

8.2.3.1.2 DIMSE Service Group

DIMSE Service Element	Usage SCU
N-SET	M

8.2.3.1.2.1 N-SET

8.2.3.1.2.1.1 Attributes

Attribute Name	Tag	Usage SCU
Image Position	(2020,0010)	M
Preformatted Grayscale Image Sequence	(2020,0110)	M
>Samples Per Pixel	(0028,0002)	M
>Photometric Interpretation	(0028,0004)	M
>Rows	(0028,0010)	M
>Columns	(0028,0011)	M
>Pixel Aspect Ratio	(0028,0034)	1\1
>Bits Allocated	(0028,0100)	M
>Bits Stored	(0028,0101)	M
>High Bit	(0028,0102)	M
>Pixel Representation	(0028,0103)	M
>Pixel Data	(7FE0,0010)	M
Polarity	(2020,0020)	Used
Referenced Overlay Sequence	(0008,1130)	Not used
>SOP Class UID	(0008,1150)	Not used
>SOP Instance UID	(0008,1155)	Not used
Configuration Information	(2010,0150)	Used, not sent if empty
Magnification Type	(2010,0060)	Used
Smoothing Type	(2010,0080)	Used, not sent if empty or magnification is not equal to CUBIC
Requested Image Size	(2020,0030)	Not used

8.2.3.1.2.1.2 Status

Service Status	Status Codes	Further Meaning	Application Behavior When receiving Status Codes
Failure	C605	Insufficient memory in printer to store the image	Appropriate message is returned to the user. Association is aborted.

8.2.3.1.2.1.3 Behavior

There is no specific behavior.

The SCU does not instruct the SCP to erase the image in the image position by setting a zero length and no value in the Attribute Preformatted Grayscale Image Sequence (2020,0110) or Preformatted Grayscale Image Sequence (2020,0111)

8.2.4 Printer SOP Class

The DICOM Print SCU AE supports the following DIMSE Service Element for the Basic Printer SOP Class. The N-EVENT_REPORT DIMSE Service element sent by the DICOM Print SCP to the local DICOM Print SCU AE. The DICOM Print SCU handles the Printer Status and Printer Status Info fields. All other received data are ignored.

The N-GET DIMSE Service element sent by the DICOM Print SCU AE requests the Remote DICOM Print SCP to give information on the Remote DICOM Printer.

8.2.4.1 IOD Description

8.2.4.1.1 IOD modules

Module	Reference	Module Description
SOP Common		Contains SOP Common information
Printer Module	0	Contains status information to monitor the printer

8.2.4.1.2 Printer Module

Attribute Name	Tag	Attribute Description
Printer Status	(2110,0010)	The behaviour defined for the following term NORMAL: Association goes on. FAILURE: Association is aborted. WARNING: Association is released except if Printer Status Info is: SUPPLY LOW SUPPLY EMPTY
Printer Status Info	(2110,0020)	The behaviour is defined for SUPPLY LOW and SUPPLY EMPTY (See upwards)
Printer Name	(2110,0030)	Printer shall return value
Manufacturer	(0008,0070)	Printer shall return value
Manufacturer Model Name	(0008,1090)	Printer shall return value
Device Serial Number	(0018,1000)	Printer shall return value
Software Versions	(0018,1020)	Printer shall return value
Date Of Last Calibration	(0018,1200)	Printer shall return value
Time Of Last Calibration	(0018,1201)	Printer shall return value

8.2.4.2 DIMSE Service Group

DIMSE Service Element	Usage SCU
N-EVENT-REPORT	M
N-GET	U

8.2.4.2.1 N-EVENT-REPORT

8.2.4.2.1.1 Attributes

Event Type Name	Event Type ID	Attribute	Tag	Usage SCU
Normal	1			
Warning	2	Printer Name	(2110,0030)	
		Printer Status Info	(2110,0020)	
Failure	3	Printer Name	(2110,0030)	
		Printer Status Info	(2110,0020)	

Note: The N-EVENT-REPORT is waited for a time defined in the file ~sdc/app-defaults/dicom_print/dprint.cfg. The default timeout is set to 30 secs

8.2.4.2.1.2 Behavior

If Printer Status is FAILURE
Signal print failure to the user
Else If Printer Status is WARNING and Printer Status Info is not equal to SUPPLY LOW or SUPPLY EMPTY
Signal print warning to the user
Else
Signal print success to the user

8.2.4.2.2N-GET

8.2.4.2.2.1 Attributes

Attribute name	Tag	Usage SCU
Printer Status	(2110,0010)	Used
Printer Status Info	(2110,0020)	Used
Printer Name	(2110,0030)	Used
Manufacturer	(0008,0070)	Used
Manufacturer Model Name	(0008,1090)	Used
Device Serial Number	(0018,1000)	Used
Software Versions	(0018,1020)	Used
Date Last Calibration	(0018,1200)	Used
Last Calibration	(0018,1201)	Used

8.2.4.2.2.2 Behavior

If Printer Status is FAILURE

Signal print failure to the user

Else If Printer Status is WARNING and Printer Status Info is not equal to SUPPLY LOW or SUPPLY EMPTY

Signal print warning to the user

Else

Signal print success to the user

8.2.5 Print Job SOP Class

This SOP Class is not supported by this implementation.

8.2.6 Basic Annotation Box SOP Class

This SOP Class is not supported by this implementation.

8.2.7 Image Overlay Box SOP Class

This SOP Class is not supported by this implementation.

9. STORAGE COMMITMENT PUSH MODEL SOP CLASS DEFINITION

9.1 INTRODUCTION

This section of the DICOM Conformance Statement specifies the Storage Commitment Push Model SOP Class, the optional attributes and service elements supported, the valid range of values for mandatory and optional attributes, and the status code behaviour.

9.2 STORAGE COMMITMENT PUSH MODEL SOP CLASS DEFINITION

9.2.1 IOD Description

9.2.1.1 STORAGE COMMITMENT MODULE

**TABLE 0-1
STORAGE COMMITMENT MODULE**

Attribute Name	Tag	Attribute Description
Transaction UID	(0008,1195)	
Retrieve AE Title	(0008,0054)	When received in N-EVENT-REPORT, it is supported but ignored.
Storage Media File-Set ID	(0088,0130)	When received in N-EVENT-REPORT, it is supported but ignored.
Storage Media File-Set UID	(0088,0140)	When received in N-EVENT-REPORT, it is supported but ignored.
Referenced SOP Sequence	(0008,1199)	
>Referenced SOP Class UID	(0008,1150)	
>Referenced SOP Instance UID	(0008,1155)	
>Retrieve AE Title	(0008,0054)	Supported but ignored
>Storage Media File-Set ID	(0088,0130)	Supported but ignored
>Storage Media File-Set UID	(0088,0140)	Supported but ignored
Referenced Study Component Sequence	(0008,1111)	Not sent.
>Referenced SOP Class UID	(0008,1150)	
>Referenced SOP Instance UID	(0008,1155)	
Failed SOP Sequence	(0008,1198)	
>Referenced SOP Class UID	(0008,1150)	
>Referenced SOP Instance UID	(0008,1155)	
>Failure Reason	(0008,1197)	All values from the following table are supported.

TABLE 0-2
FAILURE REASON VALUES AND SEMANTICS

Failure Reason	Meaning	SCU Behavior
0110H	Processing failure	Logged into log file Pop-up displayed to user to warn him that images from patient X could not be committed.
0112H	No such object instance	Logged into log file Pop-up displayed to user to warn him that images from patient X could not be committed.
0213H	Resource limitation	Logged into log file Pop-up displayed to user to warn him that images from patient X could not be committed.
0122H	Referenced SOP Class not supported	Logged into log file Pop-up displayed to user to warn him that images from patient X could not be committed.
0119H	Class / Instance conflict	Logged into log file Pop-up displayed to user to warn him that images from patient X could not be committed.
0131H	Duplicate transaction UID	Logged into log file Pop-up displayed to user to warn him that images from patient X could not be committed.

9.2.2 DIMSE Service Group

DIMSE Service Element	Usage SCU/SCP
N-EVENT-REPORT	M/M
N-ACTION	M/M

9.2.3 Operations

9.2.3.1 Action Information

**TABLE 0-3
STORAGE COMMITMENT REQUEST - ACTION INFORMATION**

Action Type Name	Action Type ID	Attribute	Tag	Requirement Type SCU/SCP
Request Storage Commitment	1	Transaction UID	(0008,1195)	1/1
		Referenced SOP Sequence	(0008,1199)	1/1
		>Referenced SOP Class UID	(0008,1150)	1/1
		>Referenced SOP Instance UID	(0008,1155)	1/1

9.2.3.2 Service Class User Behavior

N-ACTION is sent when the images are successfully sent to a remote host declared as Storage Commitment Provider on the SENOGAPHE 2000 D Acquisition Workstation.

Storage Commitment can be requested for Digital Mammography X-ray SOP Class Images For Presentation and For Processing.

Referenced Study Component Sequence Attribute is not supported.

The transaction UID is applicable until we receive the N-EVENT-REPORT.

Storage Media File-Set ID & UID Attributes in the N-ACTION are not supported.

When receiving an unsuccessful N-ACTION Response Status Code from the SCP, we log the error in a log file and we display a pop-up to the user.

9.2.3.3 Status Codes

No Service Class specific status values are defined for the N-ACTION Service. See PS 3.7 for general response status codes.

9.2.4 Notifications

9.2.4.1 Event Information

**TABLE 0-4
STORAGE COMMITMENT RESULT - EVENT INFORMATION**

Event Type Name	Event Type ID	Attribute	Tag	Requirement Type SCU/SCP
Storage Commitment Request Successful	1	Transaction UID	(0008,1195)	-/1
		Referenced SOP Sequence	(0008,1199)	-/1
		>Referenced SOP Class UID	(0008,1150)	-/1
		>Referenced SOP Instance UID	(0008,1155)	-/1
Storage Commitment Request Complete - Failures Exist	2	Transaction UID	(0008,1195)	-/1
		Referenced SOP Sequence	(0008,1199)	-/1C
		>Referenced SOP Class UID	(0008,1150)	-/1
		>Referenced SOP Instance UID	(0008,1155)	-/1
		Failed SOP Sequence	(0008,1198)	-/1
		>Referenced SOP Class UID	(0008,1150)	-/1
		>Referenced SOP Instance UID	(0008,1155)	-/1
		>Failure Reason	(0008,1197)	-/1

9.2.4.2 Service Class User Behavior

When receiving the N-EVENT-REPORT, system looks first for the SOP Instance UID successfully committed. It records them in a log file and flag them in the local database as “Committed”. Secondly, the system looks for the SOP Instance UID for which the commit failed. It also records them in a log file with the failure reason and display a pop-up to the user.

9.2.4.3 Status Codes

No Service Class specific status values are defined for the N-EVENT-REPORT Service. See PS 3.7 for general response status codes.